

The Veritas® Shooting Board Fence is designed for accurately shooting angles from 0° to 60°. It can be mounted for either right- or left-handed use on a user-made shooting board. The fixed detents on the base plate let you quickly set specific miter angles for multi-sided structures.

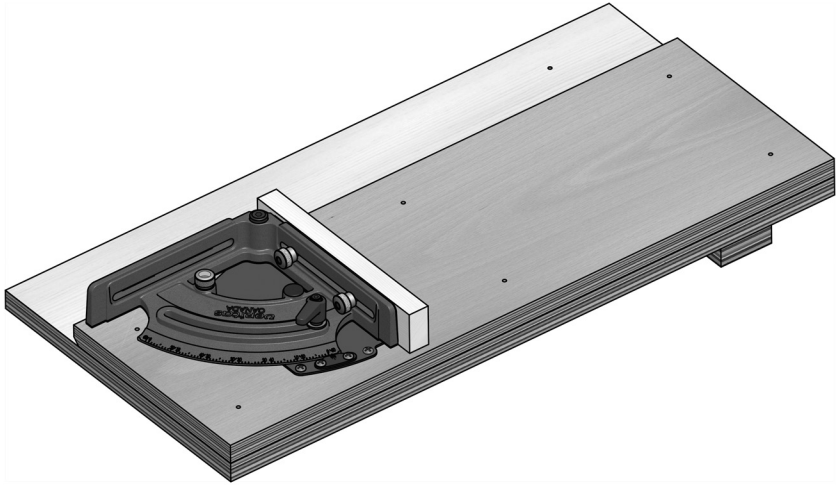

Figure 1: Veritas Shooting Board Fence mounted on a user-made shooting board.

Making a Basic Shooting Board

You can make a shooting board from three pieces of nominal 3/4" (18 mm) sheet material. High-quality plywood, MDF or laminate are good choices as these materials are dimensionally stable and have good wear properties.

To accommodate the Veritas Shooting Plane, for example, you can incorporate a “track” that is 3 1/2" wide and 23 7/8" long, as well as provide room for a guide rail.

Note: This configuration can also accommodate the 24" Veritas Shooting Board Track (05P54.82), if desired.

Note: The shooting board can be made longer or shorter to suit the plane used and the user's preference.

Note: The diagrams show a shooting board with a right-handed configuration. A left-handed board is simply the mirror image of this.

1. **Fence Panel:** The fence panel has the locating holes for the fence inserts and the detent plate. Dimensions are shown in **Figure 2**.

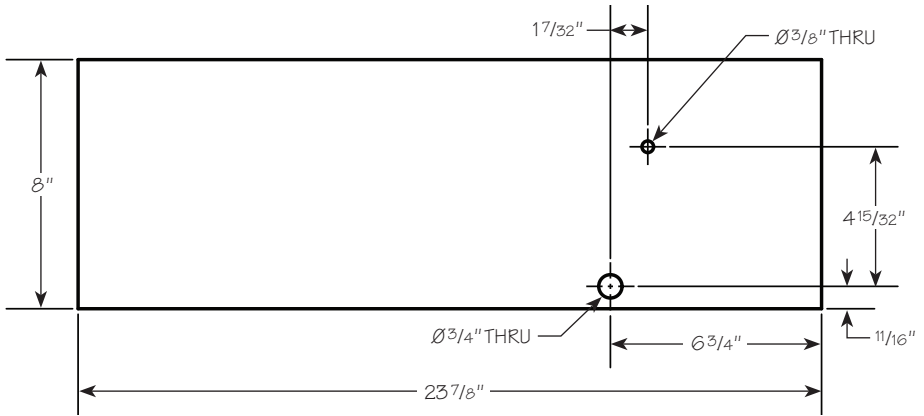

Figure 2: The dimensions for the fence panel.

The shooting plane will eventually run against the edge adjacent to the 3/4" hole, so this edge should be as straight as possible. There should be a 1/8" to 1/4" chamfer along the bottom edge of this surface to create clearance for any debris.

2. **Base Panel:** The base panel is the part on which the shooting plane runs.

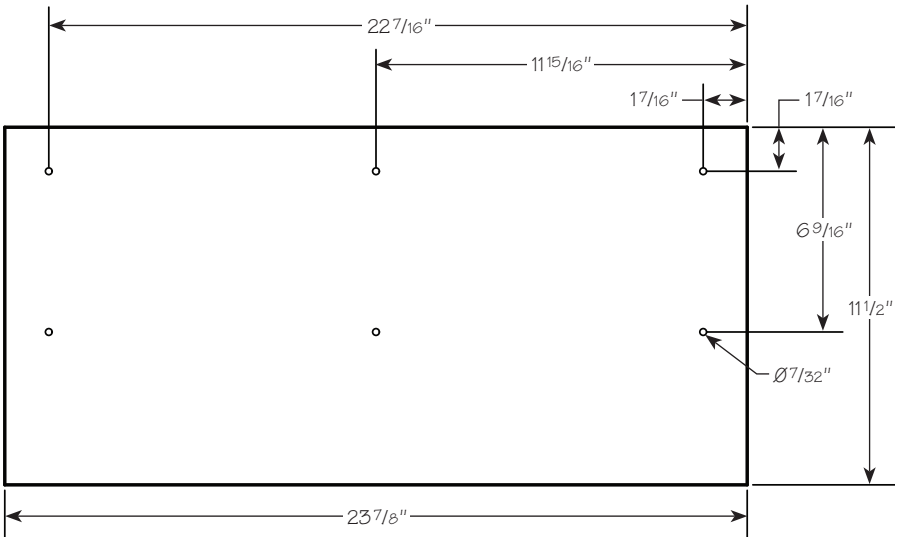

Figure 3: The dimensions for the base panel.

Align the fence panel onto the base panel and screw the components together from the bottom, using appropriate flat-head screws.

3. **Cleat:** Attach a cleat to the bottom of the base panel so the shooting board can be secured against the edge of a workbench or in a vise.

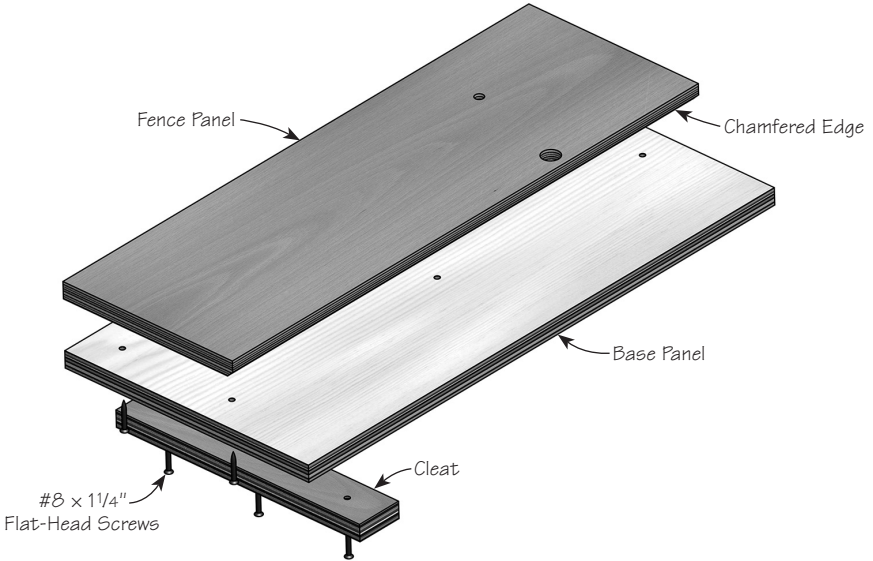

Figure 4: Assembling the shooting board.

Installing the Fence

Glue the large brass fence insert into the $\frac{3}{4}$ " hole using epoxy. The insert should be oriented with the counterbore up. Test fit before gluing to be sure the insert can be installed flush to the top surface.

Thread the smaller brass insert into the $\frac{3}{8}$ " hole. Using a $\frac{1}{4}$ -20 insert driver will ease this operation and aid in locating the insert square to the hole.

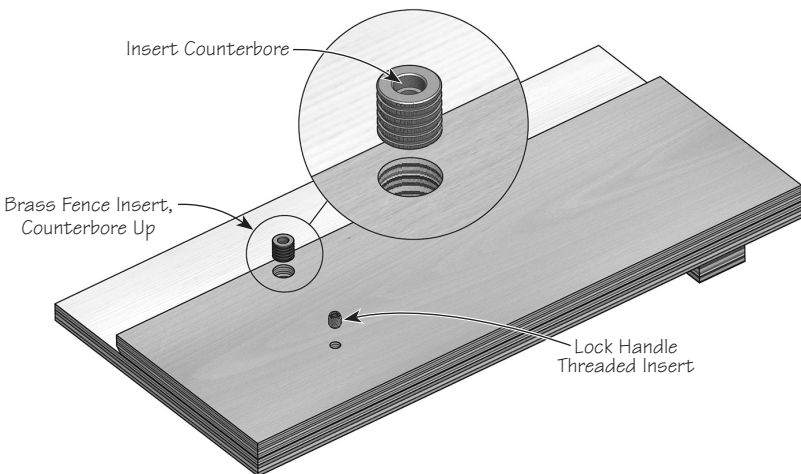

Figure 5: Installing the inserts.

Install the detent plate and the fence using the shoulder bolt. Put a small amount of releasable thread-locking adhesive on the threads of the shoulder bolt before assembly. The shoulder of the shoulder bolt should pass through the hole in the detent plate. The plate and fence should rotate freely around the shoulder bolt.

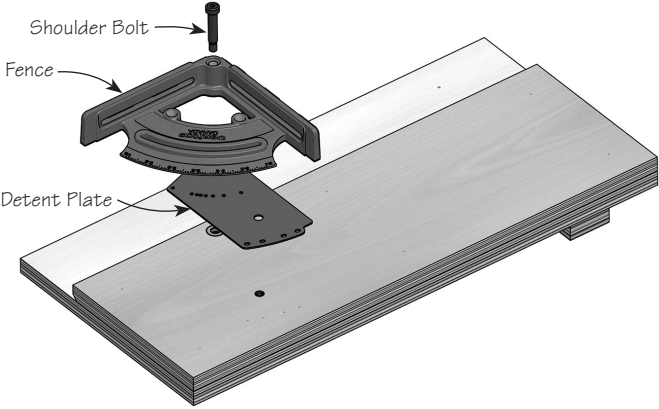

Figure 6: Installing the detent plate and fence.

Install the spring plunger in the threaded hole in the fence as shown in **Figure 7**, and install the dust cap in the other hole. (For a left-handed board, switch the location of the spring plunger and the dust cap.)

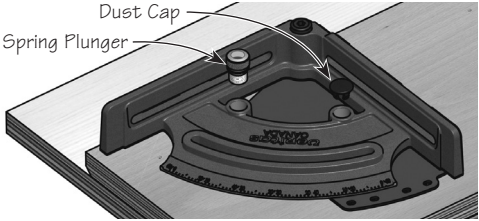

Figure 7: Installing the spring plunger.

Be sure the spring plunger is in the first hole in the detent plate as shown in **Figure 8**. The detent plate and fence should now rotate together around the shoulder bolt.

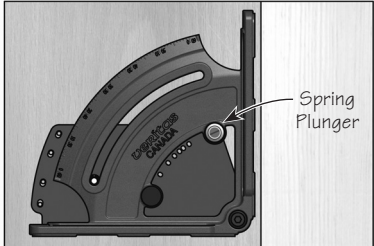

Figure 8: Spring plunger engaged in first hole in detent plate.

Verify that there is no angular play between the fence and the detent plate when the spring plunger is bottomed out in the fence. If there is, use a screwdriver to adjust the spring plunger, as shown in **Figure 8a**.

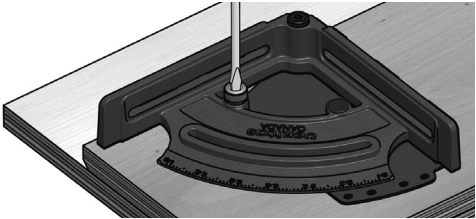

Figure 8a: Adjusting the spring plunger.

Using an accurate square, position the fence at exactly 90° to the reference surfaces of the fence panel, as shown in **Figure 9**. The square may need to be elevated to ensure that the blade contacts the reference surfaces.

Lock the fence in place by installing the gyratory handle and 1/4" washer.

Secure the detent plate to the fence panel using two pan-head screws through the outer two slots as shown in **Figure 9**. Pre-drill pilot holes for the screws centered in the slots in the detent plate.

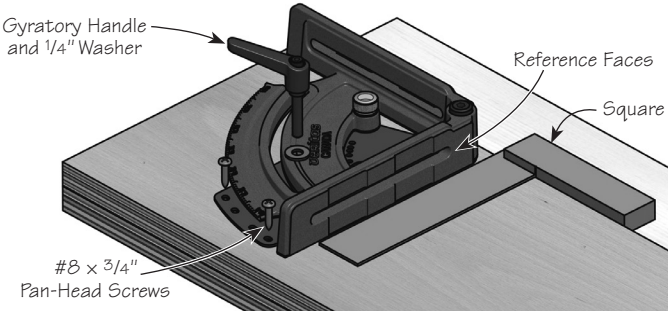

Figure 9: Positioning and securing the fence at 90° to the shooting board.

Align the middle graduation on the zero scale with the 0° graduation on the fence and secure it in place with the two remaining pan-head screws.

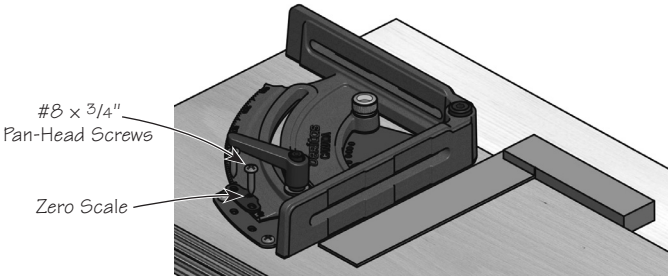

Figure 10: Aligning the zero scale.

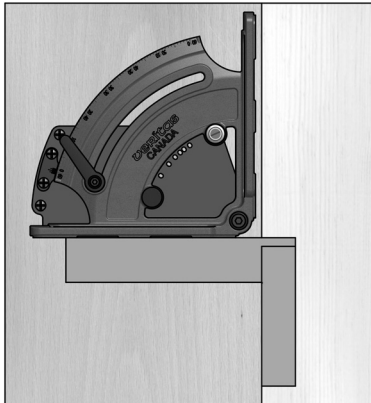

Figure 11: Final location of the fence assembly.

The shooting board fence can be used in this configuration; however, better results will be achieved if a sacrificial wood sub-fence is used to ensure the workpiece is supported right to the edge of the cut. This will also prevent blow-out on the back side of the workpiece. The sub-fence can be made from standard 1 × 2 or larger material. A softwood such as pine is preferable.

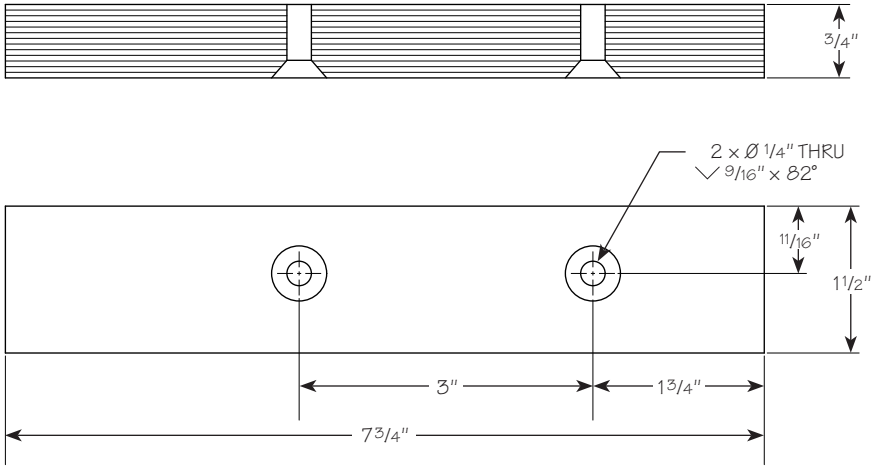

Figure 12: Dimensions for a right-hand sub-fence.

Note: A left-hand sub-fence would be a mirror image.

The 9/16" diameter countersinks should be such that the heads of the mounting screws are flush or recessed from the face of the sub-fence.

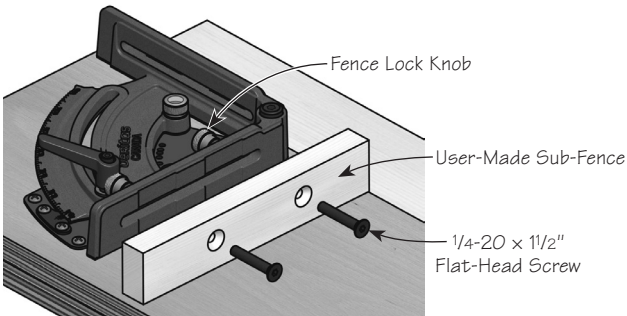

Figure 13: Installing the sub-fence.

The shooting board fence can be set accurately to within 0.25°, as shown in **Figure 14**.

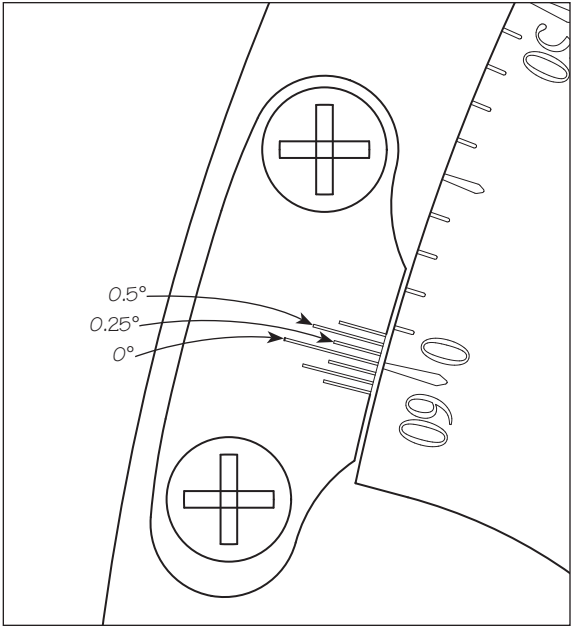

Figure 14: Setting the fence angle.

The shooting board is now ready to use. Some wax on the track surface and reference edge will make for smoother action.

Select the pre-set miter angle detent that relates to the number of sides on the structure you are making:

Angle	Number of Sides
0°	Square Corners
18°	10
22.5°	8
25.7°	7
30°	6
36°	5
45°	4
60°	3