

THE BEST
SHOP
VACUUM? p.34

Shop Disasters: Don't Let it Happen to You

ShopNotes®

Vol. 13

www.ShopNotes.com

Issue 74

EXTENDABLE DRILL PRESS TABLE

From Short to Long — This Project
Handles it All p.26

HARDWARE STORAGE CABINET

A Flexible
Solution p.12

ALSO:

**3-in-1
Table Saw
Cut-Off Sled**
Crosscuts, Miters,
& Tenons p.18

**All-New
Hinge
Mortising Jig**
Fast, Accurate,
& Foolproof p.6



ShopNotes

Issue 74

Mar./Apr. 2004

PUBLISHER Donald B. Peschke
EDITOR Terry J. Strohmman
ASSOCIATE EDITORS Bryan Nelson
 Vincent Ancona
CONTRIBUTING EDITOR Phil Huber
ART DIRECTOR Cary Christensen
SENIOR ILLUSTRATOR Roger Reiland
ILLUSTRATORS David Kallemyn
 Peter Larson
SR. GRAPHIC DESIGNER Jamie Downing

CREATIVE RESOURCES

Creative Director: Ted Krausek • *Sr. Project Designers:* Ken Munkel, Kent Welsh, Ryan Minkick, Chris Fitch • *Shop Crafters:* Steve Curtis, Steve Johnson • *Sr. Photographer:* Crayola England • *Photographer:* Tobin Bennett

SPECIAL PUBLICATIONS

Cov. V.P.: Douglas L. Hiebs • *Art Dir.:* Douglas A. Flitt • *Sr. Graphic Designers:* Chris Glowacki, Mark Hayes, Jr. • *Graphic Designer:* Katie Beckman • *Sr. Editor:* Craig Ruessgager • *Assoc. Editor:* Joel A. Hess

CIRCULATION

Circ. Oper. Director: Sandy Baum • *Circ. Marketing Dir.:* Wayne J. Klingbeil • *Strategic Business Analysts:* Kris Schlotzner, Paula M. DeMatteis • *Circ. Marketing Analyst:* Patrick Walsh • *Renewal Mgr.:* Paige Rogers • *Circ. Marketing Assoc.:* Christine Forret • *Circ. Fulfillment Mgr.:* Stephanie Forinash • *Sr. Graphic Designers:* Robin Friend, Randy Soebek

CORPORATE SERVICES

V.P. of Finance: Mary R. Schewe • *Controller:* Craig Stille • *Sr. Acct.:* Laura J. Thomas • *Acct. Payable:* Mary J. Schultz • *Acct. Receivable:* Margo Petrus • *Prod. Dir.:* George Chvickars • *Electronic Pub. Dir.:* Douglas M. Lelster • *Sys. Admin.:* Chris Schwanebeck • *P.C. Maint. Tech.:* Robert D. Cook • *Pre-Press Image Specs.:* Troy Clark, Minnie Johnson • *Assoc. Style Dir.:* Rebecca Cunningham • *New Media Mgr.:* Gordon C. Guppe • *Multimedia Art Dir.:* Eugene Pedersen • *Web Server Admin.:* Carol Schoeppler • *Web Content Mgr.:* David Briggs • *Multi-media Designer:* Kara Blessing • *Web Prod.:* Terry Walker • *Research Coord.:* Nicholas A. Jaeger • *Prof. Dev. Dir.:* Michal Sigal • *H.R. Asst.:* Kirsten Koelke • *Office Mgr.:* Natalie Lonsdale • *Facilities Mgr.:* Kurt Johnson • *Admin. Asst./Recept.:* Jeanne Johnson • *Mail Room Clerk:* Lou Webber • *Admin. Asst.:* Danielle Deknoblough

ShopNotes® (ISSN 1062-9606) is published bimonthly (Jan., March, May, July, Sept., Nov.) by August Home Publishing, 2200 Grand, Des Moines, IA 50312.

ShopNotes® is a registered trademark of August Home Publishing ©Copyright 2004 by August Home Publishing. All rights reserved. Subscriptions: Single copy: \$4.95. One year subscription (6 issues), \$27.95. Canada/International add \$10 per year, U.S. funds.

Canadian Subscriptions: Canada Post Agreement Number 40649740. Send change of address information and blocks of undeliverable copies to PO Box 381, Station Main, Markham, ON L3P 3M6.

Periodicals Postage Paid at Des Moines, IA and at additional mailing offices.

Postmaster: Send change of address to ShopNotes, P.O. Box 37108, Boone, IA 50037-2108.

Online Customer Service. www.ShopNotes.com

- Access your account
- Check a subscription payment
- Tell us if you've missed an issue
- Change your mailing or email address
- Renew your Subscription
- Pay your bill

Email: shopnotes@shopnotes.com

Write to ShopNotes, P.O. Box 842, Des Moines, IA 50304-9961 or call 1-800-333-5075, 8:00 am to 5:00 pm, Central Time, weekdays. Or send an email to: orders@shopnotes.com

AUGUST HOME
PUBLISHING COMPANY

Printed in U.S.A.

Cutoffs

A few weeks back, Vince (an associate editor here on *ShopNotes*) stopped by with quite a story. It seems that an uncle of his had just gone through a devastating disaster. He had lost his entire house and shop to a wildfire — everything was gone.

While the thought of a fire is bad enough, it wasn't until I saw some photos of the aftermath that it really hit home for me. Here and there were a few recognizable metal skeletons. But for the most part, everything seemed to be lost in a sea of black soot and ash. It made me think of my own shop and what a blow it would be to lose everything.

Vince suggested doing an article on how to deal with shop disasters. Hopefully we'll be able to help other woodworkers avoid a similar experience. And provide some ideas for ways to prepare for a disaster if you should ever have to face one.

(On a more positive note, I found out the local woodworking club that Vince's uncle belongs to is getting a

group of members together to help rebuild his shop and house.)

New Faces – We have a few new faces around here. First, Jamie Downing has joined us as our Senior Graphic Designer. (Actually Jamie has been with us a few months now, but I forgot to mention it in the last issue.)

David Kallemyn and Peter Larson have also joined our team to help with the artwork and page layout. I'm glad to have all of them on board and look forward to working with them.

Help Wanted – Besides our recent additions to art staff, I would like to add some new faces to the editorial side as well. So if you're an experienced woodworker, interested in writing, and excited about sharing your knowledge with others, we would like to here from you.

Send a resume highlighting your experience to: Human Resources, August Home Publishing, 2200 Grand Ave., Des Moines, IA, 50312. Or if you prefer you can reach us via email at: hr@augusthome.com.

Terry

Be included, as a part of the **Woodworking Shop Tours**

On the Web

Visit other *ShopNotes* subscribers' workshops and see photos of the shop projects they've built. It's all online at Woodworking Shop Tours on the *ShopNotes* web site:

www.ShopNotes.com

We want you to be part of our shop tours! To submit photos of your favorite *ShopNotes* projects or views of your shop, just follow the instructions you'll find on our web site.



Contents

Features

Hinge Mortising Jig _____ 6

Cutting a perfect mortise for a hinge on a project can be a challenge. Our new jig makes it automatic by using the hinge to set up the jig. Then a trim router does the work.

Using the Hinge Mortising Jig _____ 11

Using the hinge mortising jig couldn't be easier. Once the jig is set to match your hinge, routing a mortise will take only minutes — whether you're routing a couple or a dozen.

Hardware Storage Cabinet _____ 12

Keep hardware stored out of the way, yet easy to find, with this versatile storage cabinet. It features two different-size drawers, an adjustable partitioning system, and a unique drawer front that combines the pull and labeling system in a single unit.

3-in-1 Cut-Off Sled _____ 18

Cut-off sleds have been around a long time. What makes this one different is the reversible fences can handle 90° cuts as well as 45° miters — with precision.

Add-On Tenoning Jig _____ 24

To make the cut-off sled even more useful, you can add an easy-to-build tenoning jig. With it you can cut smooth-faced tenon cheeks quickly and accurately.

Extendable Drill Press Table _____ 26

Solve the hassle of supporting your workpiece with this drill press table. Wings extend out to provide solid support when you need it — and store out of the way when you don't.

Departments

Readers' Tips _____ 4

Shop-tested tips to solve common woodworking problems.

Shop Talk _____ 32

What would you do if you lost all your shop equipment? Here's what you need to know about shop insurance.

Tool Chest _____ 34

Quiet and powerful. Two words you don't expect in the same sentence describing a shop vacuum. But the vacuum reviewed in this issue is both — and it features automatic operation.

Sources _____ 35

Mail-order sources and supplies to help you complete the projects featured in this issue.

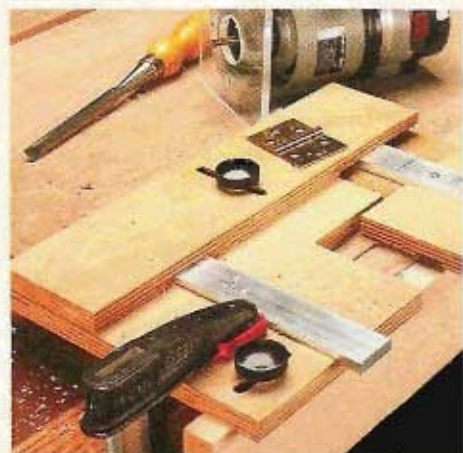

Hinge Mortising Jig page 6

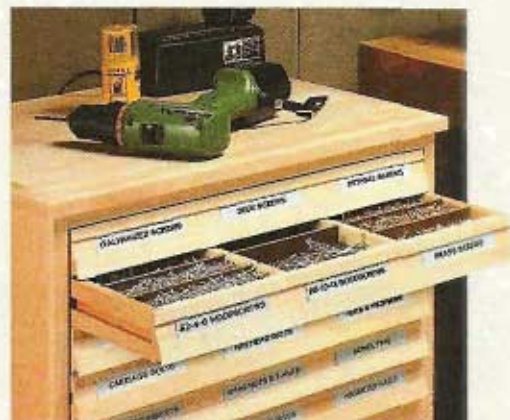

Hardware Cabinet page 12



3-in-1 Cut-Off Sled page 18



Drill Press Table page 26

Readers' Tips

Belt Sander Dust Collector



■ The drill press belt sander from *ShopNotes* No. 72 is a great way to get more from my drill press. The only trouble is that sanding creates a lot of dust. To keep the dust under control, I built a dust collector to attach to the table, as shown in the photo. Best of all, it's flexible so you can set it right where you need it.

The dust collector consists of two parts — the collector head and an adjustable arm. The head is made from $\frac{1}{4}$ " hardboard and is shaped like the nozzle of a cordless vacuum cleaner. A plywood back seals the wide end of the nozzle, as shown in detail 'a.' At the top of the back, a

hole allows you to attach the hose from a shop vacuum. At the bottom of the back piece, I fastened a plywood tab that connects the collector head to the adjustable arm.

In the drawing below, you can see the arm is made up of a series of $\frac{3}{4}$ " plywood sections. The sections are connected to each other with threaded inserts and studded knobs.

*Ben Hall
Bronx, New York*

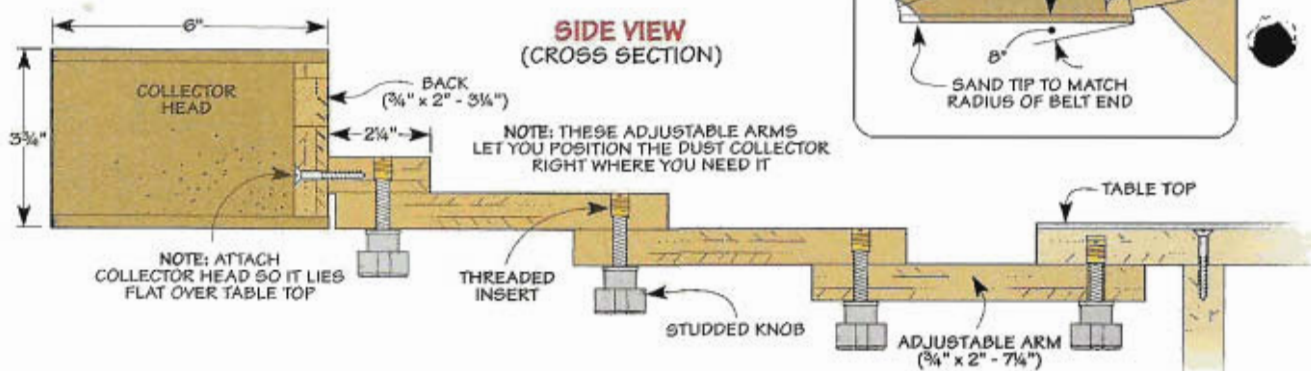

Free Tips

ON THE WEB

Get more wood-working tips free.

Visit us on the Web at ShopNotes.com

Sign up to receive a free shop tip by email every week.

Vibration Dampeners

■ With my workshop in the basement, I try to keep the noise, dust, and vibrations from disturbing the rest of the house. So to eliminate vibrations from the ceiling-mounted air cleaner, I devised a simple dampener, as shown in the drawings.

The cleaner hangs from chains that are attached to cleats with eye bolts. A piece of soft, plastic tubing surrounds the bolt and a felt pad between the washer and locknut absorb the vibrations from the cleaner, as shown in detail 'a.'

*Perry Johnson
Golden Valley, Minnesota*

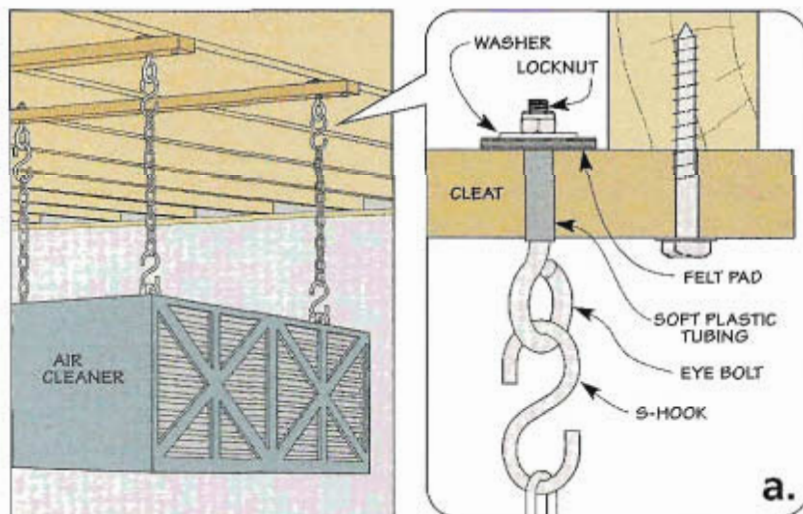

Scroll Saw Auxiliary Table

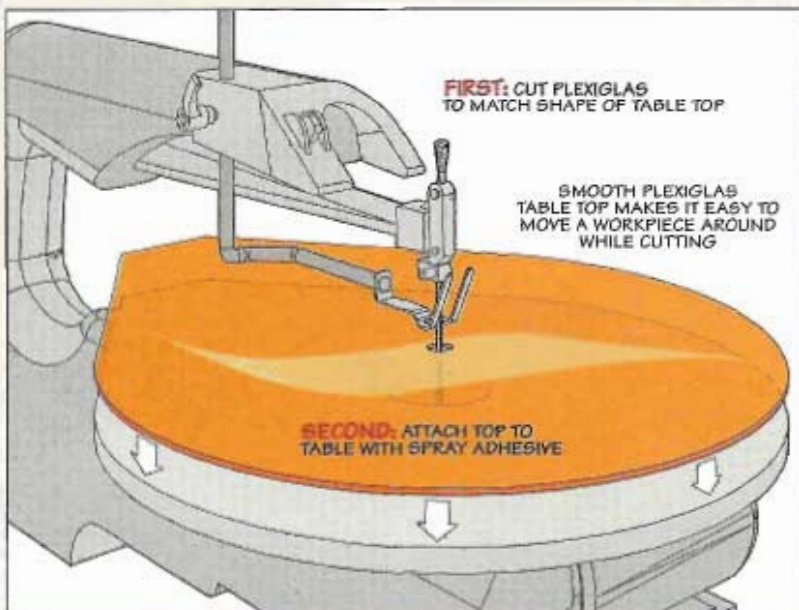

■ Most of the work I do on my scroll saw involves fine cuts on small pieces. So it's very important for the workpiece to slide easily across the table. The problem is most scroll saw tables aren't very smooth. I've tried waxing the table and found that the wax wears off pretty quickly and leaves a residue on my projects.

To solve the problem, I made a smooth sliding auxiliary top out of a piece of *Plexiglas*, as in the drawing at left. The *Plexiglas* is the same size as the saw table and has a hole a bit larger than the blade to provide more workpiece support. I attached it with spray adhesive.

Mike Zuchick
Walnut Cove, North Carolina

T-Track Work Support

■ While building some cabinet doors, I needed a way to hold them upright while installing the hinges. So I made the simple support assembly shown in the drawing.

The two L-shaped supports are made from a few pieces of $\frac{3}{4}$ "-thick stock fastened together with metal corner braces. The supports are attached to some T-track installed in my workbench with toilet bolts, washers, and knobs.

John Premo
Western Springs, Illinois

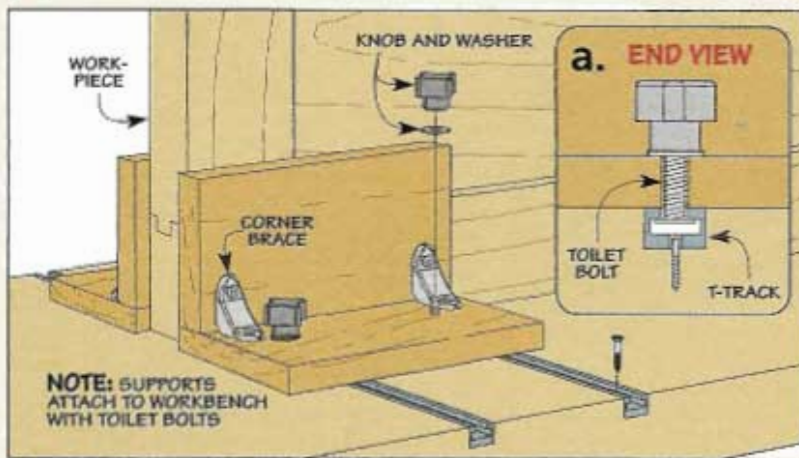

Quick Tip

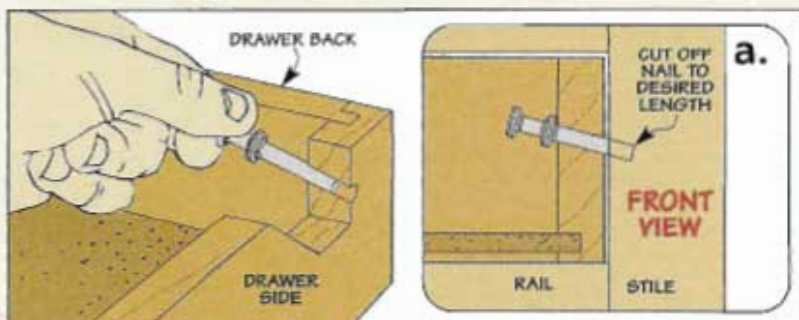

▲ To keep heavy drawers from falling out of his shop cabinets, Irvin Schmidt of Lakewood, WA slips a cut-off, double-headed nail into an angled hole in the drawer side to act as a removable stop.

Send in Your Tips

To share your original tips and solutions to problems you've faced, send them to: *ShopNotes*, Attn.: Readers' Tips, 2200 Grand Ave., Des Moines, IA 50312. (Or if it's easier, FAX them to us at: 515-282-6741.)

We'll pay up to \$200 depending on the published length. Please include a daytime phone number so we can call you if we have any questions.

Hinge Mortising Jig



A Mortise for a Hinge. Quick, clean, and accurate — that's the only way to describe the mortise you get with a trim router and this hinge mortising jig.

One of the “make it or break it” parts of building a project comes when you install hardware, especially hinges. A poorly fit hinge not only looks bad, but it can affect how well a door or lid opens and closes.

The hinge mortising jig you see above takes the hassle out of cutting a mortise for a hinge and just about makes it automatic. Worried about sizing the mortise to match the hinge? Don't. Simply use the hinge to set the jig for a perfect fit. And with the adjustability designed into the jig, you'll be able to handle hinges as small as $\frac{3}{4}$ " or as large as $3\frac{1}{8}$ ".

Trim Router – One thing you'll notice in the photo is the trim router used to rout the mortise. A trim router is most often used for working with laminate, but there are a few benefits to using one with this hinge mortising jig.

For starters, the jig can be smaller since it doesn't have to support a large router base. Plus, the small, compact size makes it easy to use with one hand. And finally, it's quite a bit less noisy than a full-size router.

Online Video – One last thing. If you'd like to see how easy it is to use the mortising jig to rout a mortise, check out our new video by visiting www.ShopNotes.com.

EXPLODED VIEW
OVERALL DIMENSIONS:
13½"W x 7½"D x 4½"H

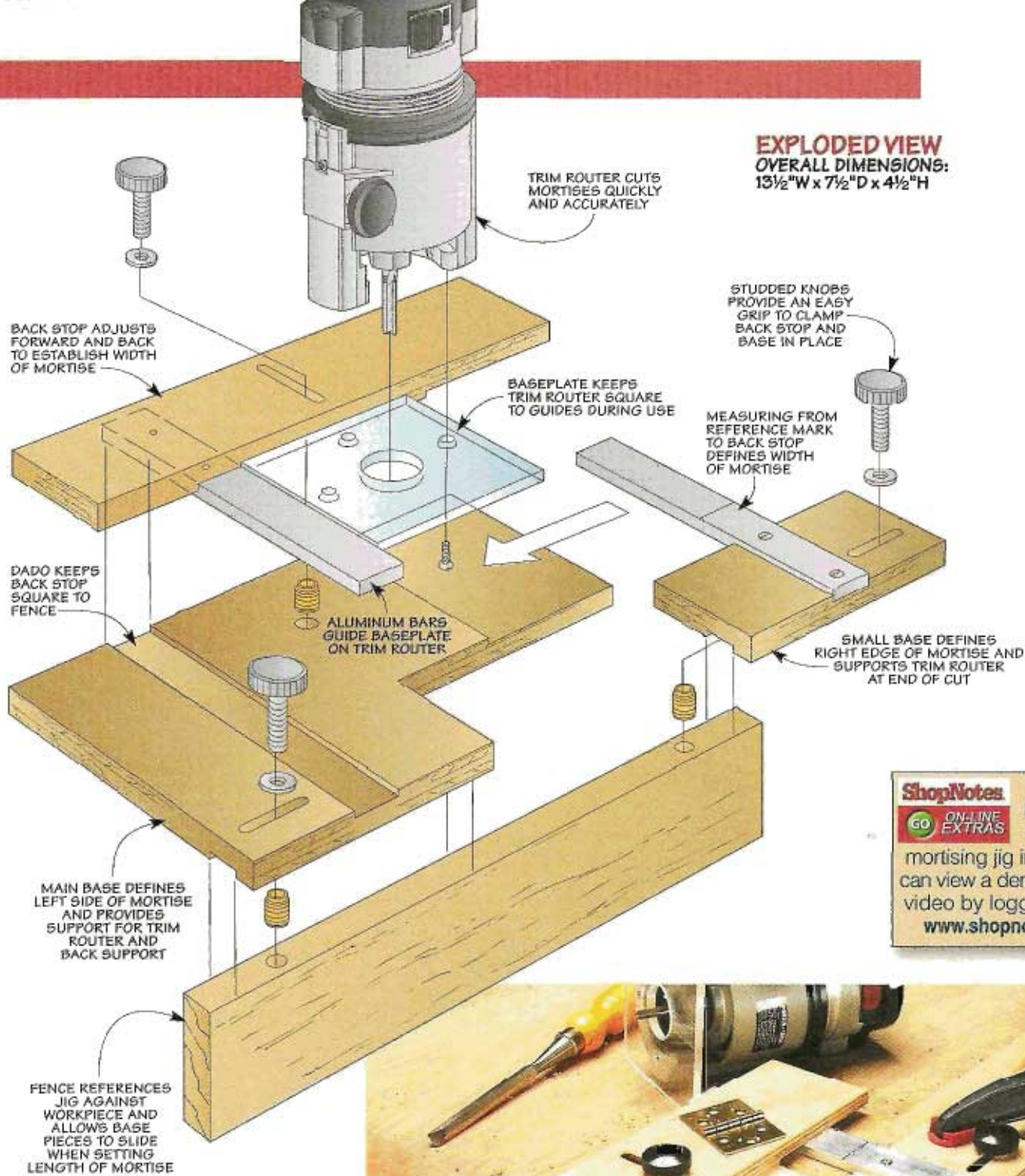

ShopNotes If you'd like to see the hinge mortising jig in use, you can view a demonstration video by logging on to: www.shopnotes.com

GO ONLINE EXTRAS

Hardware & Materials

- | | | |
|---|----------------|--|
| A | Small Base (1) | 2 ¹ / ₁₆ x 5 ⁷ / ₁₆ - 1/2 Ply. |
| B | Main Base (1) | 7 ¹ / ₂ x 11 - 1/2 Ply. |
| C | Back Stop (1) | 2 ³ / ₄ x 11 - 1/2 Ply. |
| D | Fence (1) | 3/4 x 2 ³ / ₄ - 13 ¹ / ₂ |
| E | Baseplate (1) | 4 x 4 - 1/4 Plexiglas |
- (4) #6 x 1/2" Fh Woodscrews
 - (2) 1/4" x 1" - 7/2" Aluminum Bars
 - (3) 1/4" Threaded Brass Inserts
 - (3) 1/4" x 1" Round Studded Knobs
 - (3) 1/4" Flat Washers

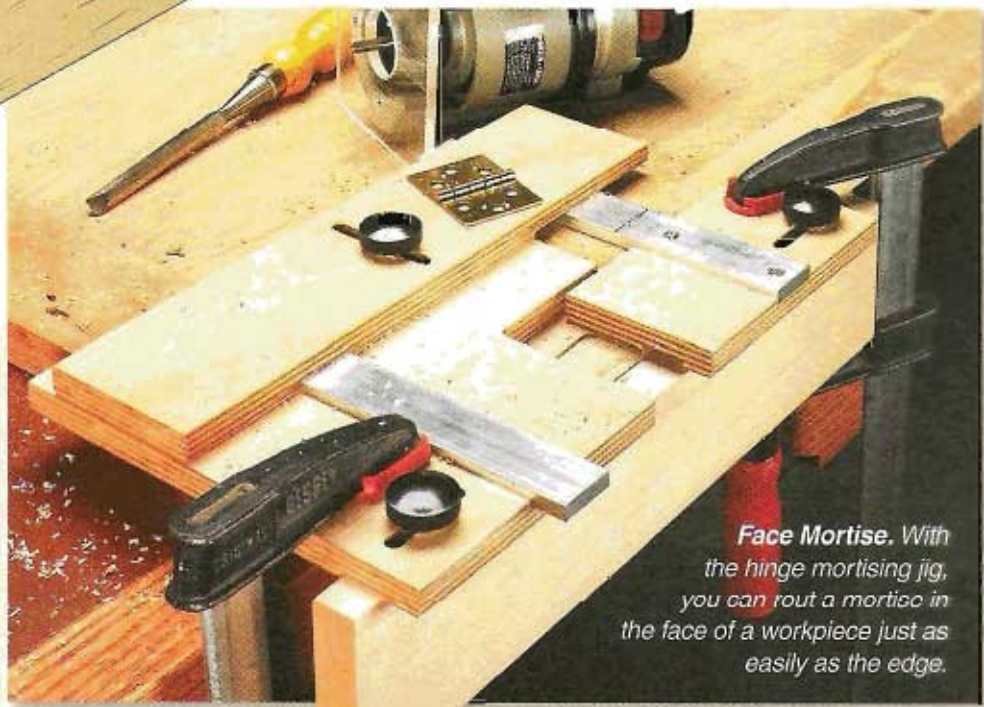

Face Mortise. With the hinge mortising jig, you can rout a mortise in the face of a workpiece just as easily as the edge.

Two-Part Base, Stop, & Fence

1 OVERVIEW

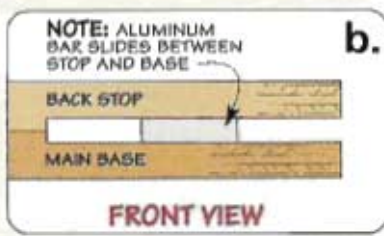
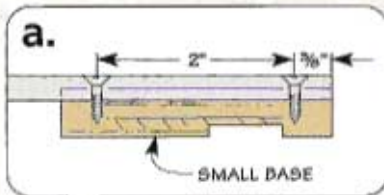
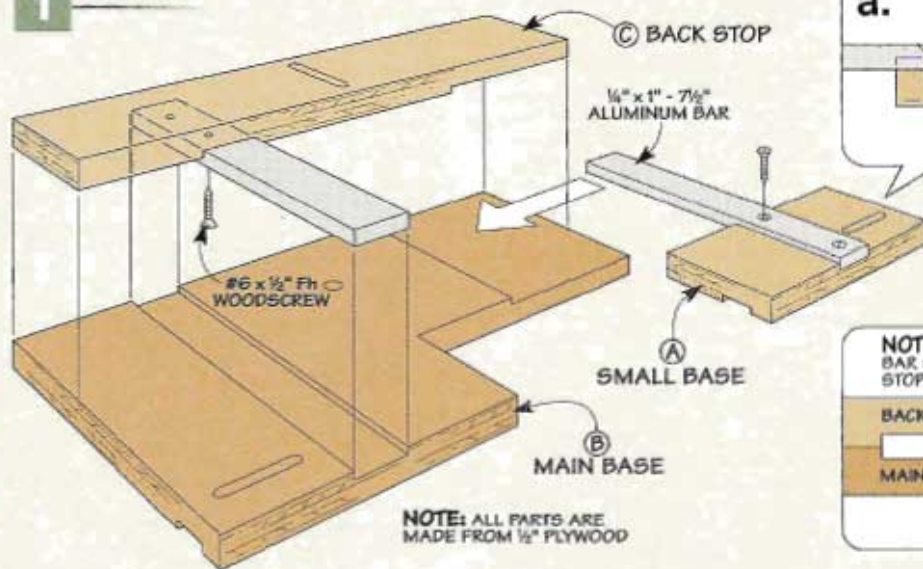

▲ Countersink.
Drill a deep countersink to ensure the screw head is below the surface of the bar.

NOTE: ALL PARTS ARE MADE FROM 1/2\"/>

To get a tight-fitting mortise, you need to control two things — the width and length of the mortise. To do this, the mortising jig consists of a two-part base, an adjustable stop, and a pair of aluminum guide bars. An overview of how these parts fit together is illustrated in Figure 1.

Start With One Piece — As you can see in the drawing, the aluminum guide bars fit into dados and rabbets cut in the base parts and the adjustable stop. Instead of working with each part individually as I cut the dados and rabbets, I found it easiest to start with a single

blank — and then cut it into separate pieces once the joinery was complete, as in Figure 2. Working with a larger piece is easier and safer — and it pretty much guarantees that the dados and rabbets will align perfectly with each other.

The first thing I did was cut a single groove in the *bottom* of the blank. This groove is sized to match the thickness of the fence (3/4") that's added later, like you see in Figure 5.

Once the groove was complete, I cut the dados you see in Step 1 of Figure 2. These two dados are cut in the *top* of the blank and sized to fit the aluminum bars that act as guides for the base of the trim router.

The only thing to keep in mind here is to be sure to cut the dados at least *half* the thickness of the bar, as shown in Figure 1b. A hair deeper is fine, but if they're too shallow the back stop on the jig won't rest against the base during use.

Finally, to allow you to lock the base pieces and back stop in place, you'll need to cut a series of slots and holes for the adjusting knobs and an insert. You can see where these are located in Step 1 of Figure 2.

Cut the Base Apart — Now you're ready to do what I talked about earlier — start cutting the main parts of the jig from the blank.

2 FIGURE

NOTE: ALL SLOTS ARE 1/4\"/>

FIRST: CUT GROOVE ON BOTTOM FACE OF BLANK (DETAIL 'a') AND DADOES ON TOP OF BLANK

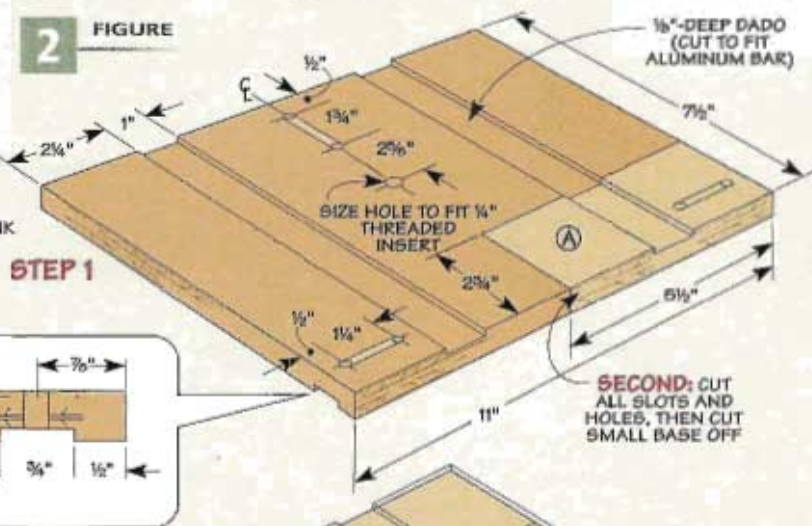

STEP 1

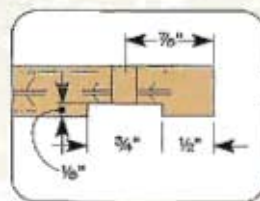

SECOND: CUT ALL SLOTS AND HOLES, THEN CUT SMALL BASE OFF

SECOND: TRIM BACK STOP FROM MAIN BASE

STEP 2

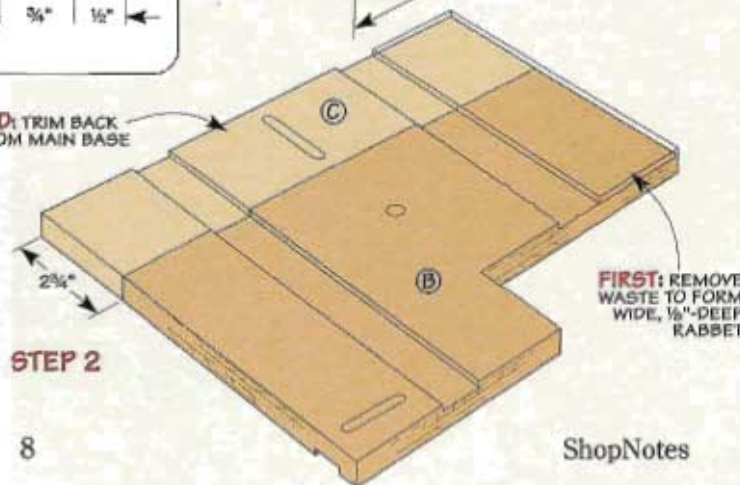

FIRST: REMOVE WASTE TO FORM WIDE, 1/2\"/>

The first step is to form the *small base (A)*. I did this by making a pair of intersecting cuts on the band saw. Doing this on the band saw allows you to leave your table saw and dado blade set up. This way, you can easily go back and cut the wide rabbet on the "leg" of the blank. You can see all this clearly in Step 2 of Figure 2 and in Figure 4.

Form the Main Base & Stop – All that's left to do at this point is trim a narrow strip off the back of the blank to form the *main base (B)* and *back stop (C)*. Once that's complete, cut the aluminum guide bars to length and screw one to the back stop and the other to the small base, like you see illustrated in Figure 1.

To see how the construction process resulted in perfectly matched dadoes and rabbets, just flip the back stop over and set it in place.

Make the Fence – With the main part of the jig assembled, you're ready to start on the fence. The fence references the jig against the workpiece and provides a way to clamp the jig in place.

The *fence (D)* is just a piece of $\frac{3}{4}$ "-thick hardwood that fits the groove cut in the bottom of the base.

Install the Inserts – After cutting the fence to final size, all that's

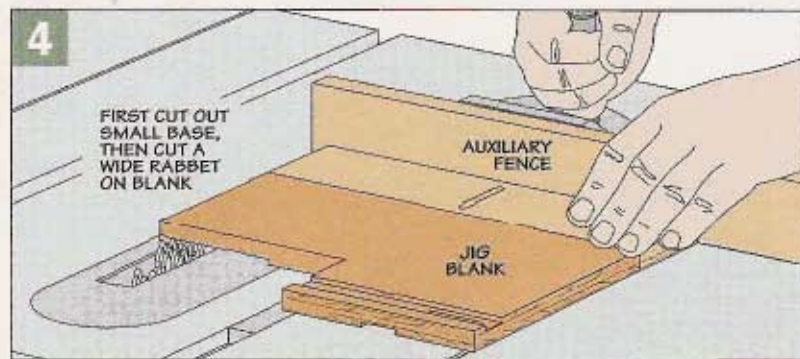
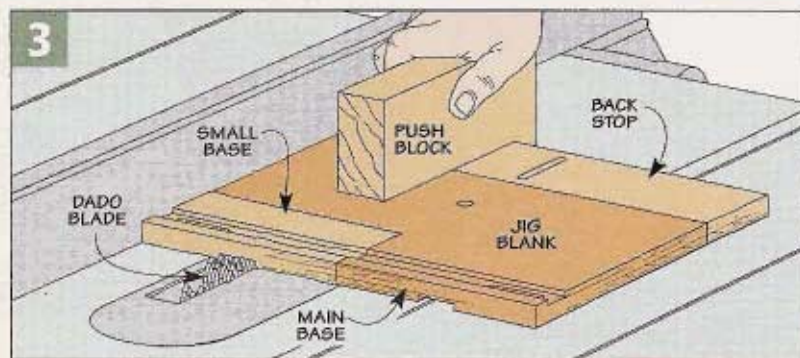

left to do is add the rest of the hardware. A threaded insert at each end of the fence accepts the studded knobs that allow you to clamp the base pieces in place once you set the jig for the length of the mortise, like you see in Figure 5a.

The Shop Tip below shows a handy way to install the inserts perfectly straight. This method requires

nothing more than a cut-off bolt and a couple hex nuts. Just be sure to turn the chuck *by hand* as you press it down with the drill press lever.

Finally, don't forget to install a threaded insert in the main base. Note: Depending on how thick your plywood actually is, you may have to file or sand the insert flush with the bottom face of the base.

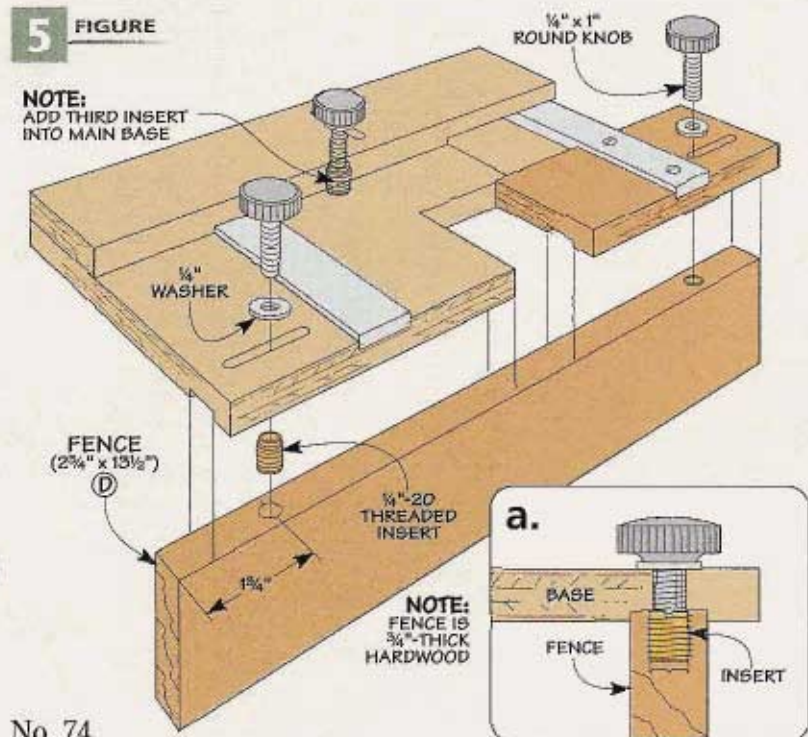

▲ **Installing Inserts.** A quick and easy way to install an insert perfectly straight is to use a cut-off bolt, a pair of hex nuts, and a drill press.

Final Details

Although the basic construction of the jig is complete, there are still a few things left to do before you can use it to rout a mortise for a hinge.

Add an Auxiliary Plate – The first thing you'll want to do is add an auxiliary baseplate to your trim router, like the one you see in the photo. The auxiliary baseplate serves two purposes.

First, using a square piece of clear plastic for the baseplate provides better visibility and more support during use. And second, it limits where the router bit cuts to match the hinge you're installing. You can see how I added the baseplate by looking at Figure 6.

Create a Custom Fit — As I mentioned earlier, the jig will automatically take care of sizing the mortise to match the width and length of the hinge. But to do this, you first have to custom fit the opening for

New Baseplate.

To improve accuracy and visibility, replace the round baseplate with a square piece of clear plastic.



your baseplate and the router bit you'll be using to rout the mortises.

Note: The jig is designed to be used with a 1/4"-dia. straight bit. This will allow you to rout a mortise for a hinge as small as 3/4" long.

Start by sliding the two base pieces all the way open. And then slide the stop to the back. Next, you'll need to cut past the bottom face of each base. After adjusting the depth of cut to 5/8", rout clockwise around the inside of the jig, keeping the baseplate against the guides and stop (Figure 7).

"Zeroing Out" the Stop – The last step is to "zero out" the stop so

you can easily set the width of the mortise. To do this, clamp a scrap against the inside face of the fence and adjust the stop so the cutting edge of the router bit is just touching the scrap when the back edge of the baseplate is against the stop, as illustrated in Figure 8a.

After you lock the back stop in place, use a scratch awl to scribe a mark on the top of the aluminum bar. You can see this in Figure 8.

Using the Jig – With the scribe mark in place, using the jig is just a matter of following the four-step process on the opposite page.

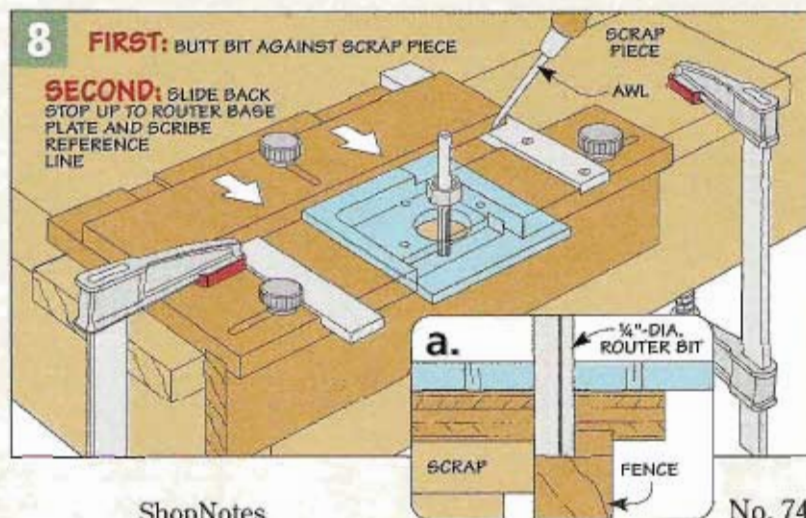
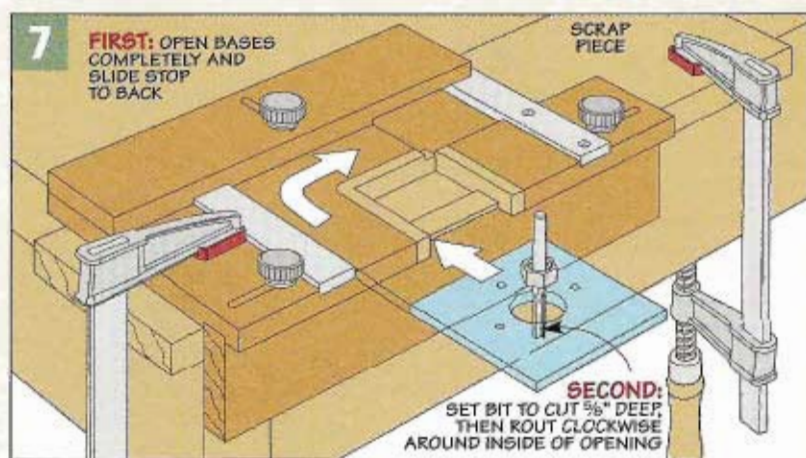
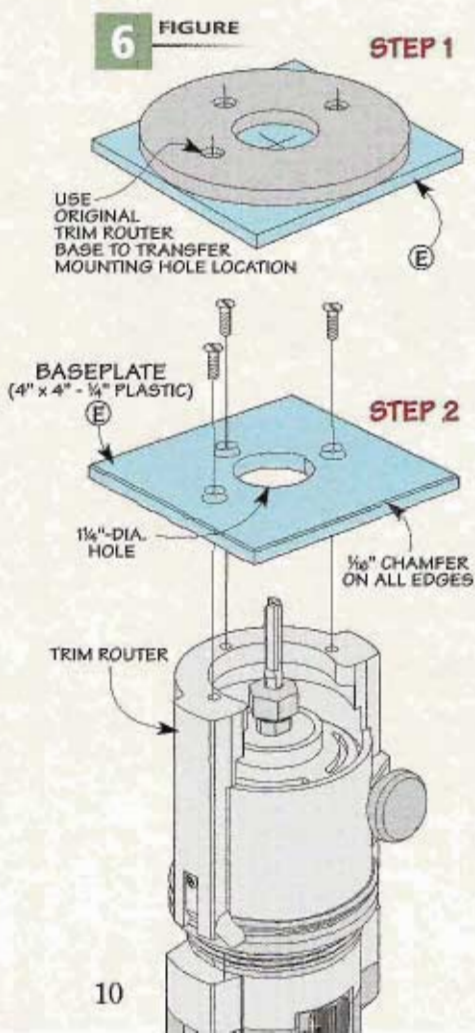

Get Great Results with the Hinge Mortising Jig

Using the mortising jig is almost foolproof. The photo sequence below shows you just about everything you need to know. But there are a couple things to keep in mind.

Hinge Lay Out - Before you clamp the jig in place, you'll need to lay out the location of each hinge. Since the jig will handle the overall length of the mortise, all you need to do is locate one edge of each hinge, like you see in the photo at the upper right. Once that's complete, you're ready to start.

Setting the Jig - Step 1 shows how to use the hinge to set the length of the mortise. In a similar

manner, Step 2 shows how to use the hinge to set the width of the mortise.

Depth of Cut - When it comes to setting the router bit to cut the mortise to depth, you need to consider your project design, such as what size gap you want around the edges of a door, and the overall thickness of the hinge itself.

Once you have the depth determined, be sure to account for the thickness of the jig base. Step 3 shows how I do this with a scrap.

Rout the Mortise - With the jig set, all that's left to do is clamp it in place, aligning the inside edge of the



▲ **Lay Out Location.** The first step in routing a mortise for a hinge is to lay out the location of the hinge along the edge of the workpiece.

jig with your layout mark. After turning the router on, rout clockwise around on the inside of the opening, keeping the baseplate against the guides and back stop.

Once that's complete, remove the rest of the waste by nibbling it away with the router. Finally, remove the jig and square up the corners of the mortise with a chisel. 🛠️



1 To set the length of the mortise, you can use the hinge to position the two parts of the base. Just be sure the inside edge of each base contacts the leaves of the hinge.

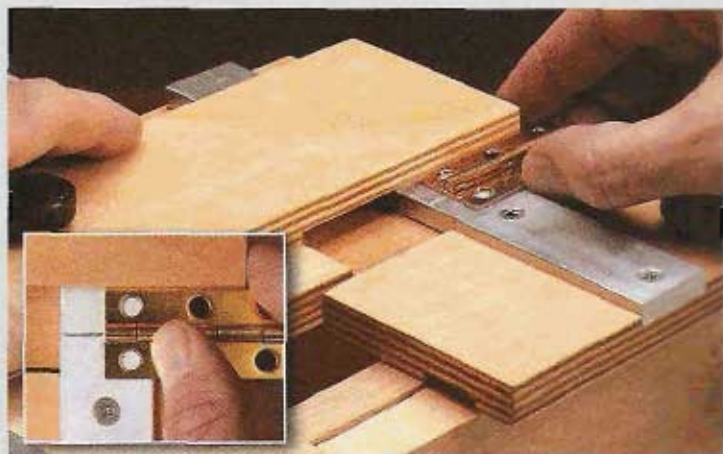

2 Here again, you can use the hinge to set the width of the mortise. A typical installation is to adjust the back stop until the centerline of the knuckle lines up with the scribe mark (see inset).

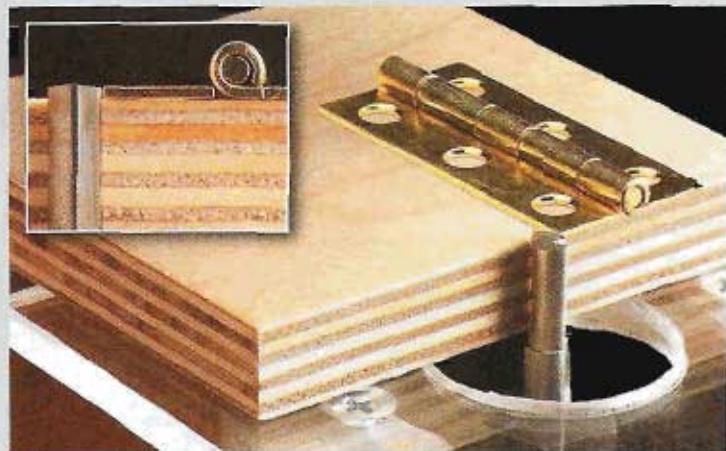

3 The depth of a hinge mortise often depends on the project design. In the photos above, a 1/2" spacer simulates the base of the jig while setting the bit to match the depth of the hinge leaf.

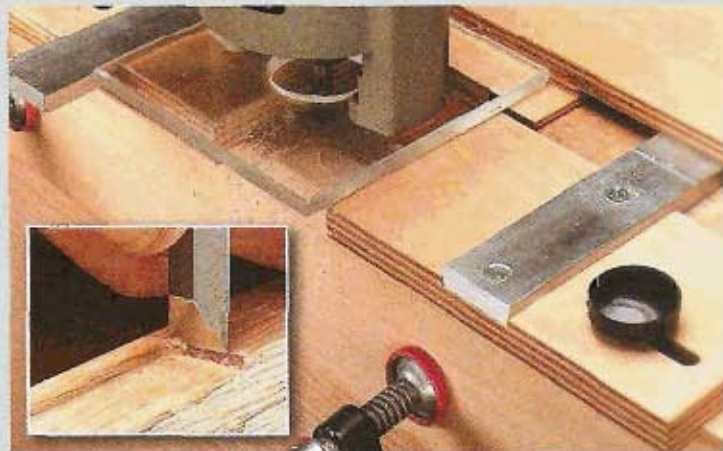

4 To remove most of the waste, rout clockwise around the inside edges of the aluminum guides and back stop. Then using the mortise as a guide, square up the corners with a sharp chisel (inset).

Hardware Storage Cabinet



It doesn't matter what I'm stopping at the hardware store to buy, somehow I always seem to drift over to the aisle that contains the hardware — things like nuts, bolts, and screws.

But it's not really the hardware that I find interesting. It's the bank of wide, flat drawers that hold the hardware. Open any one of them and inside you'll discover neatly organized compartments, each one with its own special contents. This one holds tiny machine screws, that one holds all sizes of wing nuts, and here's a drawer that holds some kind of fastener I've never even seen before.

That's the inspiration behind this hardware storage cabinet. The drawers all ride on wood runners, so they slide nice and smooth. Inside each drawer there are plenty of compartments to help you keep all your hardware separated and organized. And the deeper drawers are great for other supplies, or even hand tools. But as a woodworker, the part of this cabinet that I like the most is the drawer pulls. I'll tell you more about those a little bit later.

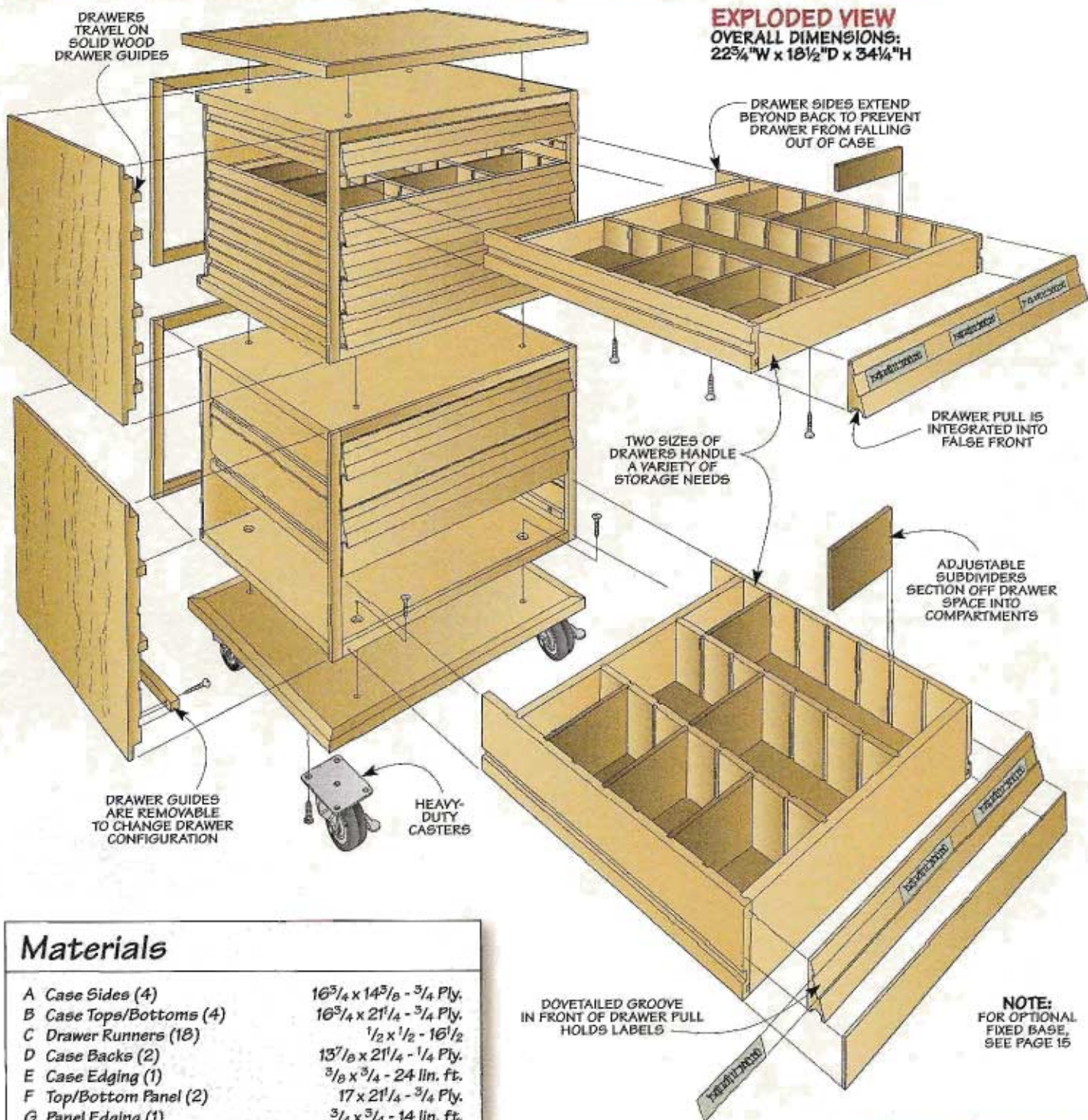

EXPLODED VIEW
OVERALL DIMENSIONS:
 22³/₄" W x 18¹/₂" D x 34¹/₄" H

Materials

A Case Sides (4)	16 ³ / ₄ x 14 ³ / ₈ - 3/4 Ply.
B Case Tops/Bottoms (4)	16 ³ / ₄ x 21 ¹ / ₄ - 3/4 Ply.
C Drawer Runners (18)	1/2 x 1/2 - 16 ¹ / ₂
D Case Backs (2)	13 ⁷ / ₈ x 21 ¹ / ₄ - 1/4 Ply.
E Case Edging (1)	3/8 x 3/4 - 24 lin. ft.
F Top/Bottom Panel (2)	17 x 21 ¹ / ₄ - 3/4 Ply.
G Panel Edging (1)	3/4 x 3/4 - 14 lin. ft.
H Small Drwr. Frt./Backs (12)	1/2 x 2 - 19 ¹ / ₄
I Small Drwr. Sides (12)	1/2 x 2 - 16 ³ / ₄
J Large Drwr. Frt./Backs (12)	1/2 x 4 ¹ / ₈ - 19 ¹ / ₄
K Large Drwr. Sides (12)	1/2 x 4 ¹ / ₈ - 16 ³ / ₄
L Small Drwr. Dividers (12)	1/2 x 1 ¹ / ₂ - 14
M Large Drwr. Dividers (6)	1/2 x 3 ⁵ / ₈ - 14
N Drawer Bottoms (9)	14 ¹ / ₄ x 19 ¹ / ₂ - 1/4 Hdbd.
O Drawer Pulls (9)	3/4 x 2 - 20
P Drawer Filler Plates (3)	1/8 x 2 ¹ / ₈ - 20
Q Small Subdividers (108)	1 ¹ / ₂ x 6 ¹ / ₄ - 1/4 Hdbd.
R Large Subdividers (54)	3 ⁵ / ₈ x 6 ¹ / ₄ - 1/4 Hdbd.

DOVETAILED GROOVE
 IN FRONT OF DRAWER PULL
 HOLDS LABELS

NOTE:
 FOR OPTIONAL
 FIXED BASE,
 SEE PAGE 15

Hardware

- (72) #8 x 3/4" Fh Woodscrews
- (12) #8 x 1/4" Fh Woodscrews
- (4) #8 x 2" Fh Woodscrews
- (24) 4d Finish Nails
- (16) #6 x 3/4" Fh Woodscrews
- (4) 3" Locking Swivel Casters
- (16) #12 x 1/4" Ph Woodscrews
- (32) 5/8" Brads

ShopNotes

GO ON-LINE
 EXTRAS

To download
 a free cutting
 diagram for
 the Storage Cabinet, go to:
www.shopnotes.com

Cases

This hardware storage cabinet is really two cabinets — one stacked on top of the other. As you can see in Figure 1, the two cases that make up the cabinet are identical. This makes the construction a little easier and also gives you the option of building just one of the cases if you want a smaller storage unit for the top of your workbench.

Case Construction — Each case is just an open plywood box. The case sides (A), and case top and bottom (B) are cut to size out of $\frac{3}{4}$ " plywood. Then the ends of the case sides are rabbeted to hold the top and bottom (Figures 1a and 1b).

After cutting the rabbets, you'll need to cut dadoes in the sides to hold the drawer runners (see drawing in margin). I cut these on the table saw, using a dado blade. And as you can see in Figure 3, I cut the dadoes in pairs, flipping the workpiece around between each cut. Once this is done, you can cut a rabbet along the back edge of the case sides, top, and bottom to hold a plywood back.

Before assembling the case, I made the drawer runners (C) and screwed them to the sides of the case. It's easier to install them at this point rather than having to reach inside the assembled case to drive

1 OVERVIEW

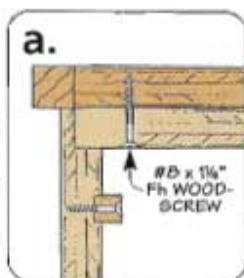

NOTE: TOP CABINET SHOWN WITH 12 RUNNERS, BOTTOM CABINET SHOWN WITH 6 RUNNERS

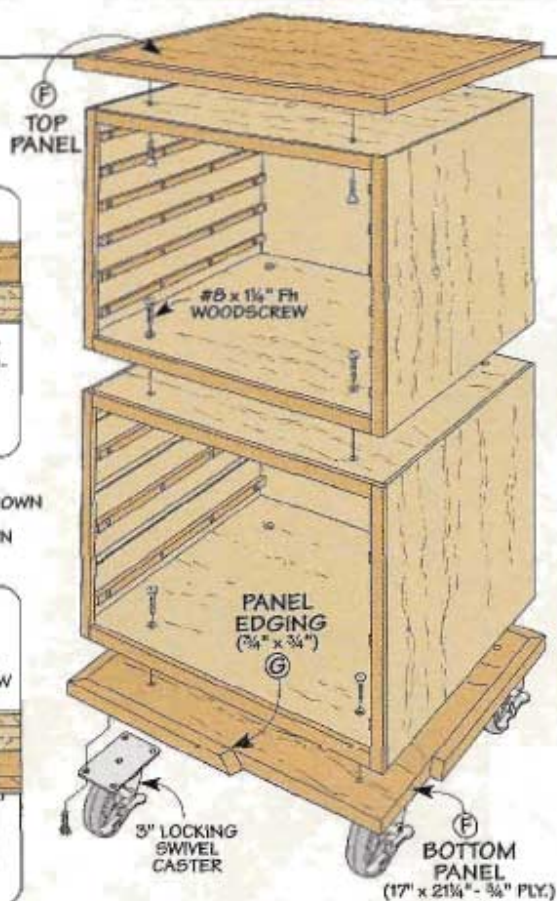
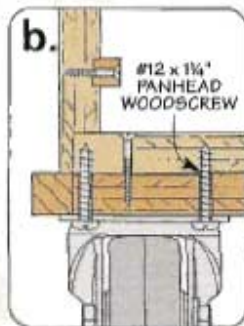

FRONT VIEW

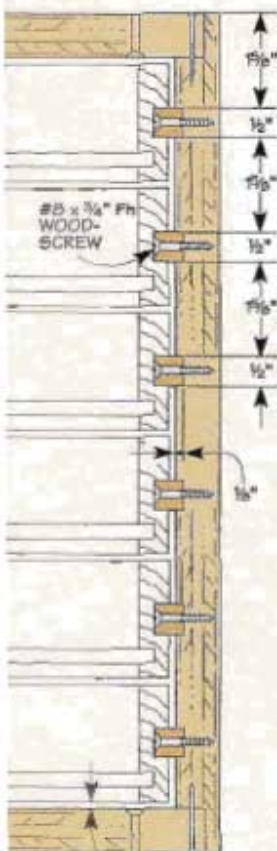

NOTE: SMALL DRAWERS SHOWN WITH $\frac{1}{8}$ " GAP ON ALL 4 SIDES

2 FIGURE

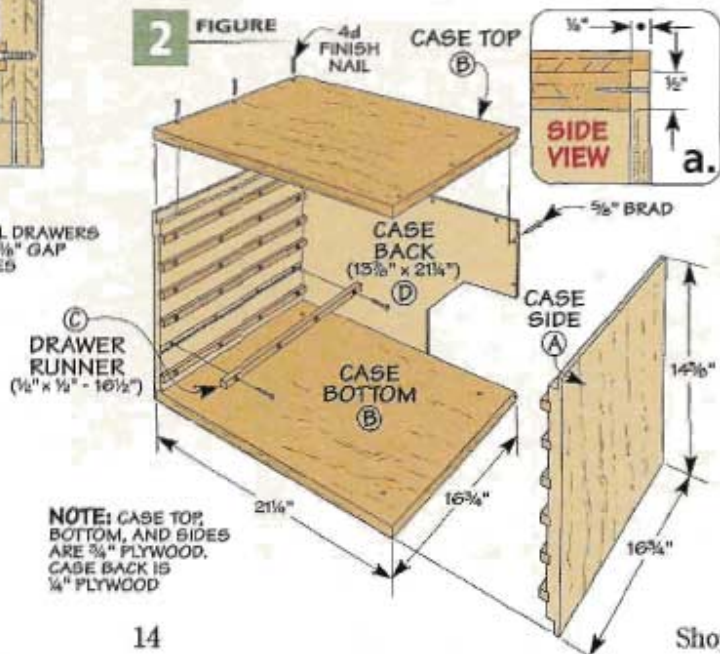

NOTE: CASE TOP, BOTTOM, AND SIDES ARE $\frac{3}{4}$ " PLYWOOD. CASE BACK IS $\frac{1}{4}$ " PLYWOOD

the screws. There's one thing to note about the drawer runners. If you take a look at the photo on page 12, you'll see that there are two sizes of drawers. If you are going to be making the deep (tall) drawers, then you'll only need to screw runners into every other dado (see the lower case in Figure 1). But if you are

making the shallow drawers, you'll need a runner in every dado. (I'll explain a little more about this when it comes time to make the drawers.)

Assembly — The case is assembled with glue and a few finish nails driven in from the top and bottom. (These surfaces will be covered later.) Once this is done, you can cut

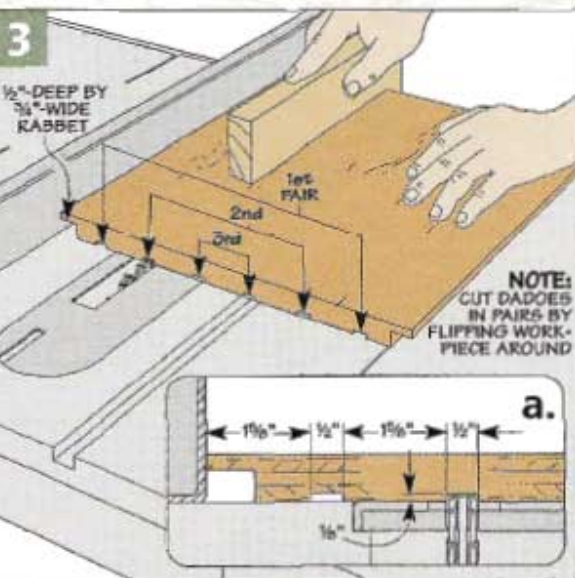

a plywood back (D) to fit in the rabbeted opening. The back is just nailed in place with some small brads. The trim pieces that you will add next will cover up these brads.

Edging - To hide the exposed edges of the plywood, I added some hardwood case edging (E) all around the front and back edges of the case, just as you see in Figure 4. This edging also hides the dados that hold the drawer runners.

Normally when I glue edging onto plywood, I make the edging extra wide and then flush trim it after it's been glued in place. But with this project, the drawer runners would get in the way of the router bit when trying to trim the inside edges. So you'll have to be a little more careful when gluing on the trim.

You can still make the trim pieces a little wider than needed, but just glue them on so they are flush with the inside walls of the case. Then use a router to trim the outer edges flush with the case.

Top & Bottom - At this point, you can connect the two cases by driving a few screws through the

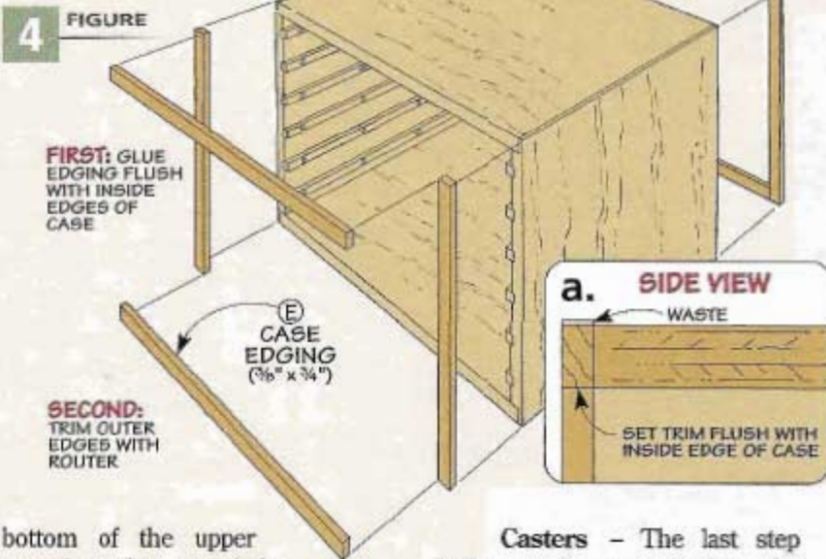

bottom of the upper case into the top of the lower case (Figure 1). Then to give the cabinet a more finished look, I sandwiched the cases between two top and bottom panels (F). These panels are identical. As Figure 1 shows, they are both just 3/4" plywood panels with some mitered hardwood edging (G) glued around all four edges. Once the edging is attached, the panels are simply screwed in place, as shown in Figures 1a and 1b.

Casters - The last step before moving on to making the drawers is to add some casters to the bottom of the cabinet (Figures 1 and 1b). Casters allow you to easily move the cabinet if you want to sweep underneath it or roll it right up near a project you're working on. The casters are just screwed directly to the underside of the bottom panel.

If you'd rather have the cabinet in a fixed location in your shop, you might want to consider building the optional base shown below.

Optional Fixed Base



If mobility isn't a big concern, you might want to consider building the fixed base you see in the photo here. The advantage of making this base over simply setting the cabinet directly on the floor is that it raises the cabinet up a few inches, making it easier to reach the bottom drawers.

The base is really nothing more than a mitered frame. The top, back, and sides of the frame are joined with splined miter joints, as you see in detail 'a.' After the base is assembled, the bottom panel is screwed to the top edges of the frame (before it is attached to the case). Then the cabinet is screwed in place to the bottom panel.

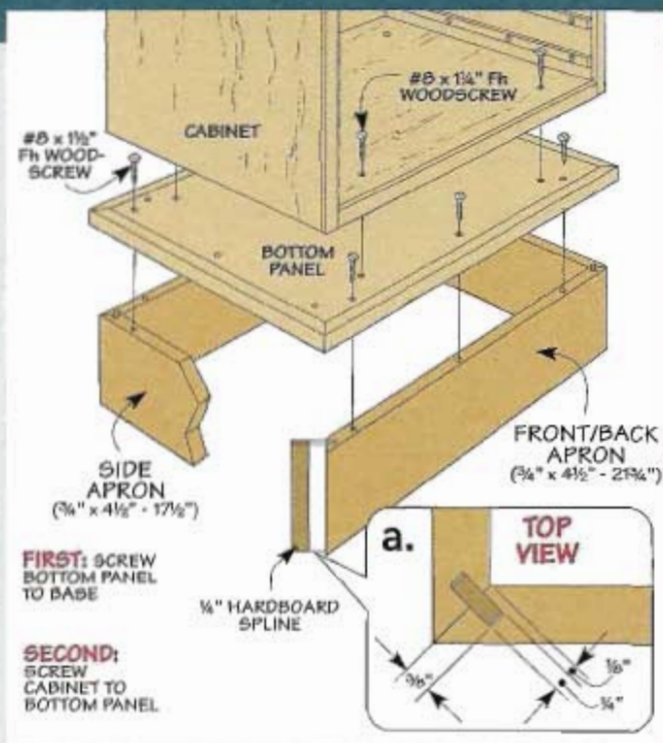

Drawers

But the really interesting thing about these drawers are the pulls. Each pull is shaped out of a blank of solid wood and doubles as a false front for the drawer. On the front of the pull is a dovetail-shaped groove that can be used to hold labels to identify the contents of the drawer.

Drawer Construction – Other than their heights, all the drawers are identical. The drawer fronts and backs are joined to the sides with tongue and dado joints. And each drawer is fitted with a pair of solid wood dividers that hold a number of smaller subdividers.

To make the drawers, start by cutting the drawer fronts and backs to size, as you see in Figure 5. Then you can cut tongues on the ends of each piece, as well as a pair of dados on the inside face of each piece to hold the drawer dividers. Figure 5a shows this pretty clearly.

To make the drawer sides and dividers, I started with extra-wide blanks that were cut to length. This way, you can cut a series of dados in each blank for the drawer fronts, backs, and subdividers, and then rip the individual sides and dividers to width (see Figure 6).

There are just a couple of things to point out when making the drawer sides and dividers. First, if you take a look at Figure 6a, you'll see that the drawer dividers have dados on both faces, while the drawer sides are dadoed on the inside face only. Second, even though the blanks I used for the drawer sides and dividers all started out the same length, the dividers will need to be trimmed to final length.

Grooves – Before you can start to assemble the drawers, you still need to cut a few grooves. First, a narrow groove is cut on the inside face of the

▲ **Get a Grip.**
A uniquely designed drawer front incorporates a finger grip as well as a holder for labels.

■ One of the interesting features about this cabinet is the drawers. If you take a look at the photo above, you'll see that there are two drawer sizes. Since the large drawers are twice as tall as the small drawers, you can re-arrange them within the cabinet by simply adding or taking out drawer runners (see photo on back cover).

5 OVERVIEW

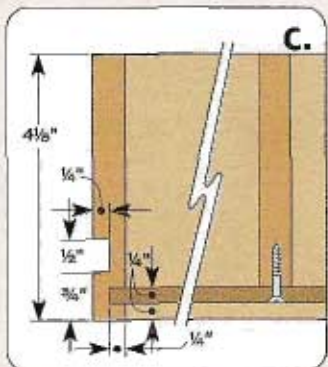
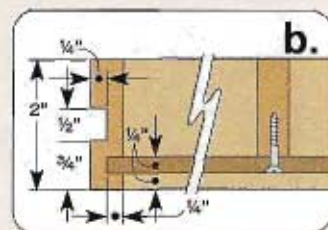
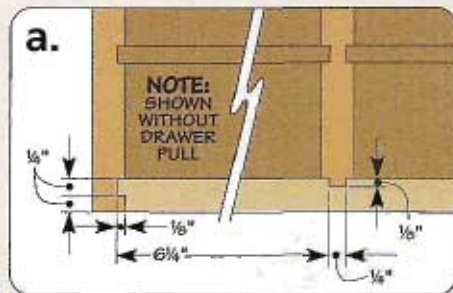
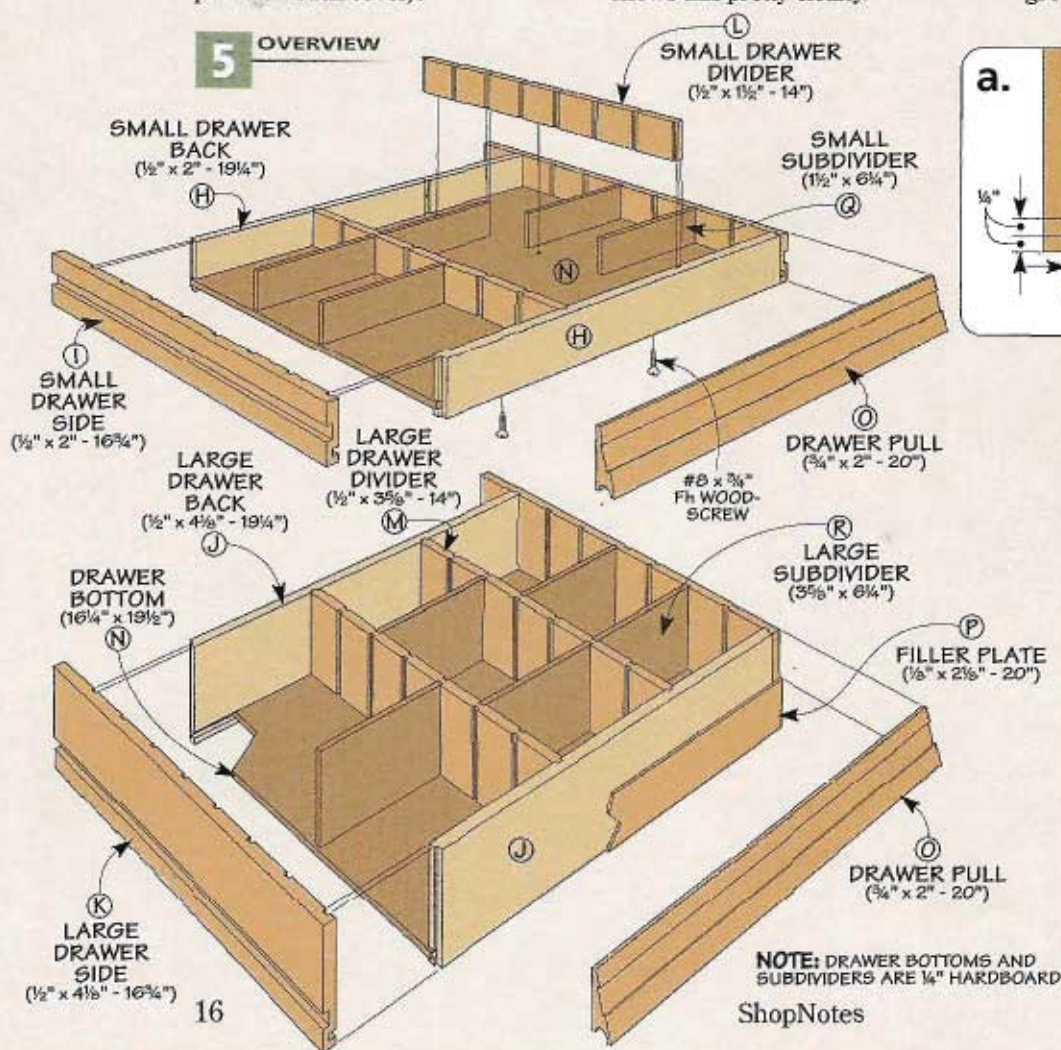

drawer fronts, backs, and sides for a hardboard drawer bottom. And then a wider groove is cut on the outside face of the drawer sides to allow the drawer to fit over the runners.

Assembly – After cutting out the drawer bottoms, you can go ahead and glue up the drawers along with the hardwood dividers. A couple of screws help secure each divider to the drawer bottom.

Pulls – One of the last steps is to add the drawer pulls (see box below). These are simply glued to the front of each drawer. For the deeper drawers, you'll also need to make a filler plate to glue to the front of the drawer just beneath the pull (Figure 5). Once the drawers are installed in the cabinet, all that's left is to cut some subdividers out of hardboard and start filling up the compartments with hardware.

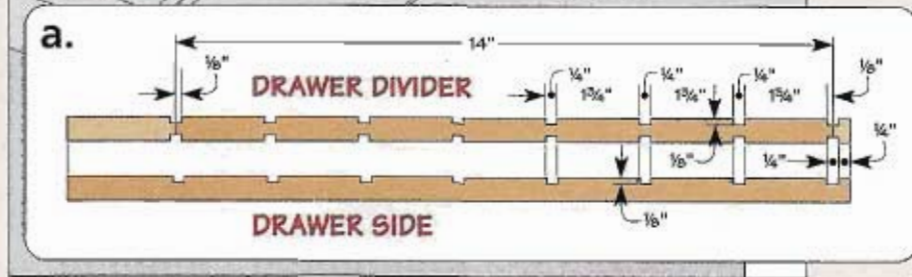
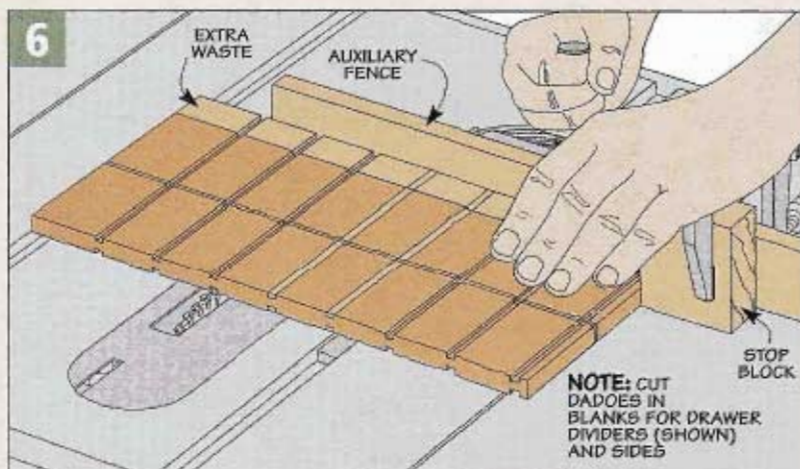

Making Drawer Pulls

Making the drawer pulls for the hardware cabinet is a three-step procedure. You start by creating a tapered blank for each pull. To do this, I made a simple sled to hold the blanks at the proper angle while running them through the thickness planer. The planer creates a nice, smooth taper. Figure 1 shows how I went about it.

Once you've got all your blanks ready, the next step is to rout a

shallow dovetail on the front of each pull. This slot will be used to hold labels to identify the contents of the drawer. A router table and a dovetail bit are all you need for this, as shown in Figure 2.

The final step is to create a hollow along the bottom edge of the pull to serve as a grip for your fingers. Again, I did this on the router table, but this time using a core box bit, as you see in Figure 3.

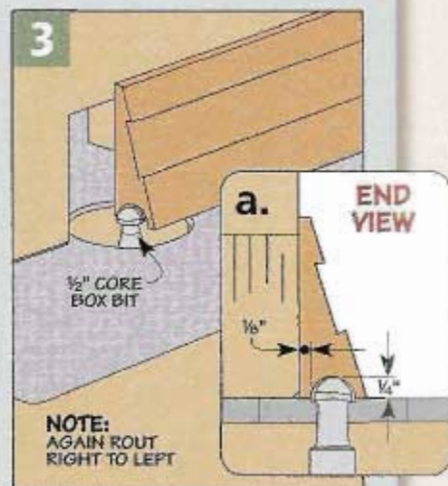
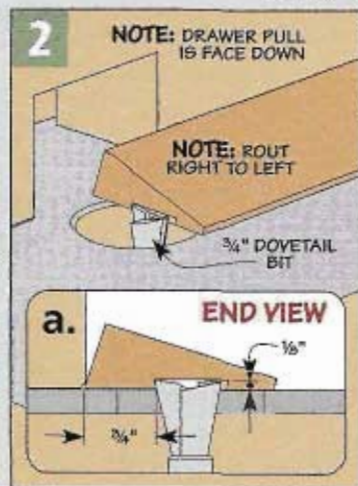
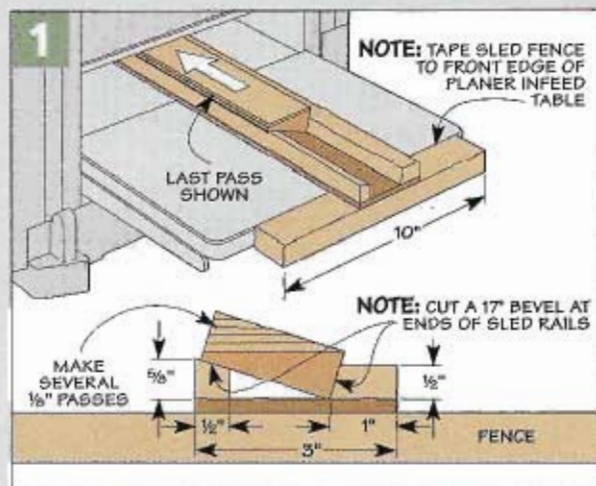
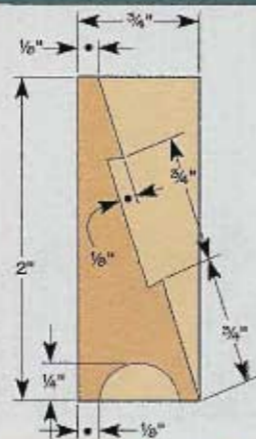

3-In-1 Cut-Off Sled

Reversible fences make this cut-off sled the perfect choice for accurate crosscuts and miters. For even more versatility, you can build the add-on tenoning jig.



Want to make your table saw more versatile? And more accurate at the same time? Well, take a look at the 3-in-1 table saw cut-off sled shown above.

Whether you're cutting small workpieces to final length, or squaring up the ends of a large panel, you can be sure they're perfectly square. The construction of the jig and sliding fences ensure the accuracy is built-in.

Square crosscuts aren't the only thing you can do accurately with this sled. Simply reverse the fences like you see in the inset photo and you can cut tight-fitting 45° miters for just about any project.



If perfect crosscuts and miters haven't sold you on this sled, then check out the opposite page for a third way to use this cut-off sled — an add-on tenoning jig. The jig holds a workpiece securely in place while you cut the cheeks of a tenon perfectly smooth.

Materials & Hardware

A Base (1)	24 x 30 - 1/2 Ply.
B Miter Block (1)	6 x 12 - 1/2 Ply.
C Stiffeners (2)	3 1/2 x 10 - 1 Ply.
D Blade Housing (1)	3 1/2 x 5 - 1 Ply.
E Fence Base (2)	6 x 14 15/16 - 1/2 Ply.
F Front Face (2)	1 1/4 x 14 15/16 - 1/2 Ply.
G Miter Face (2)	1 1/4 x 8 1/4 - 1/2 Ply.
H Tenon Jig Base (1)	8 x 14 - 1/2 Ply.
I Vertical Support (1)	8 x 8 - 1 Ply.
J Stop (1)	3/4 x 1 - 8
K Braces (2)	5 x 7 - 1/2 Ply.

- (19) #6 x 1/2" Fh Woodscrews
- (22) #8 x 1" Fh Woodscrews
- (8) #8 x 1 1/2" Fh Woodscrews
- (2) 1/8" x 2" x 14 15/16" Aluminum Bar
- (8) 1/4"-20 Threaded Brass Inserts
- (2) Adjustable Miter Bar (18" Long)
- (4) #8 x 3/4" Fh Woodscrews
- (4) 1/4" x 1" Studded Knobs
- (4) 5/16" x 1 1/4" Fender Washers
- (1) 1/8" x 3/4" x 10 5/16" Aluminum Bar
- (1) 5-Star Knob w/ 1/8"-18 Insert
- (1) 5/16"-18 Flange Bolt (3 1/2" Long)
- (1) T-Track (7" Long)
- (1) Metal Hold-down
- (1) 5/16" Washer

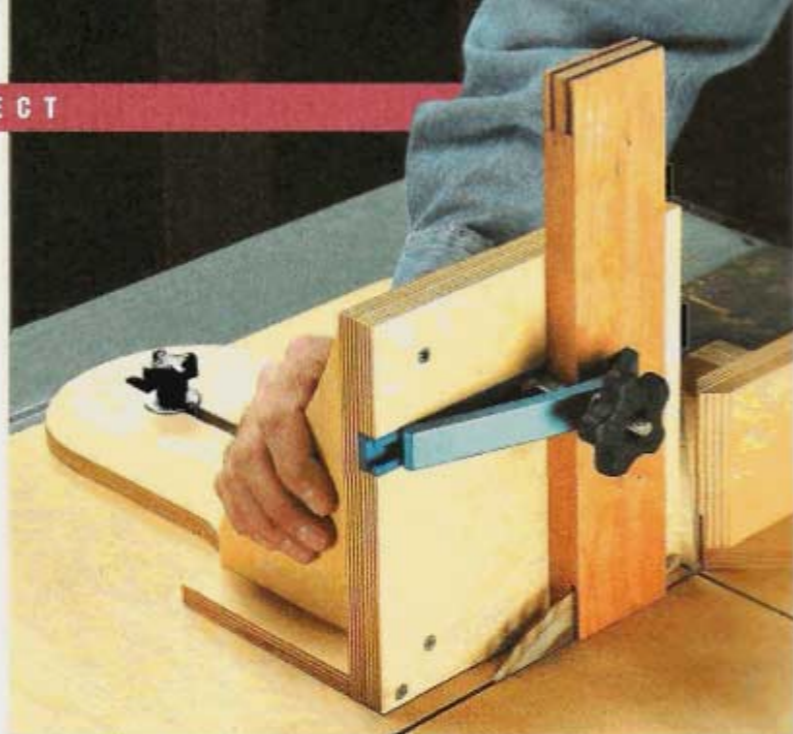

▲ **Add-On Tenoning Jig.** Cutting the cheeks of a tenon that are perfectly smooth is fast, easy, and accurate with the tenoning jig shown above. The jig mounts to the cut-off sled in place of the fence and features a replaceable stop and sturdy hold-down.

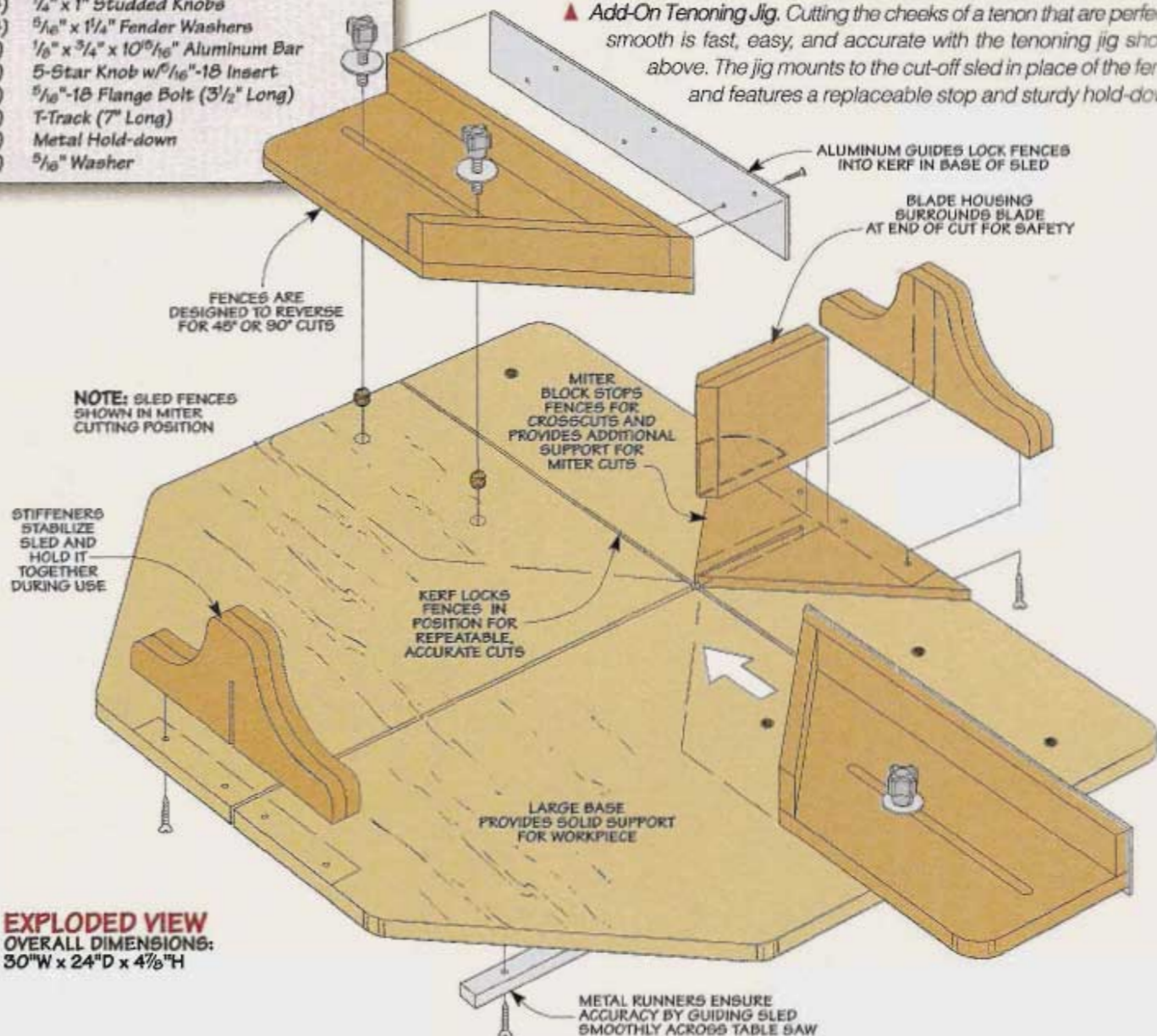

EXPLODED VIEW
OVERALL DIMENSIONS:
30"W x 24"D x 4 7/8"H

Base

1 OVERVIEW

NOTE: BASE AND MITER BLOCK ARE 1/2" PLYWOOD; STIFFENERS AND BLADE HOUSING ARE GLUED UP FROM TWO LAYERS OF 1/2" PLYWOOD

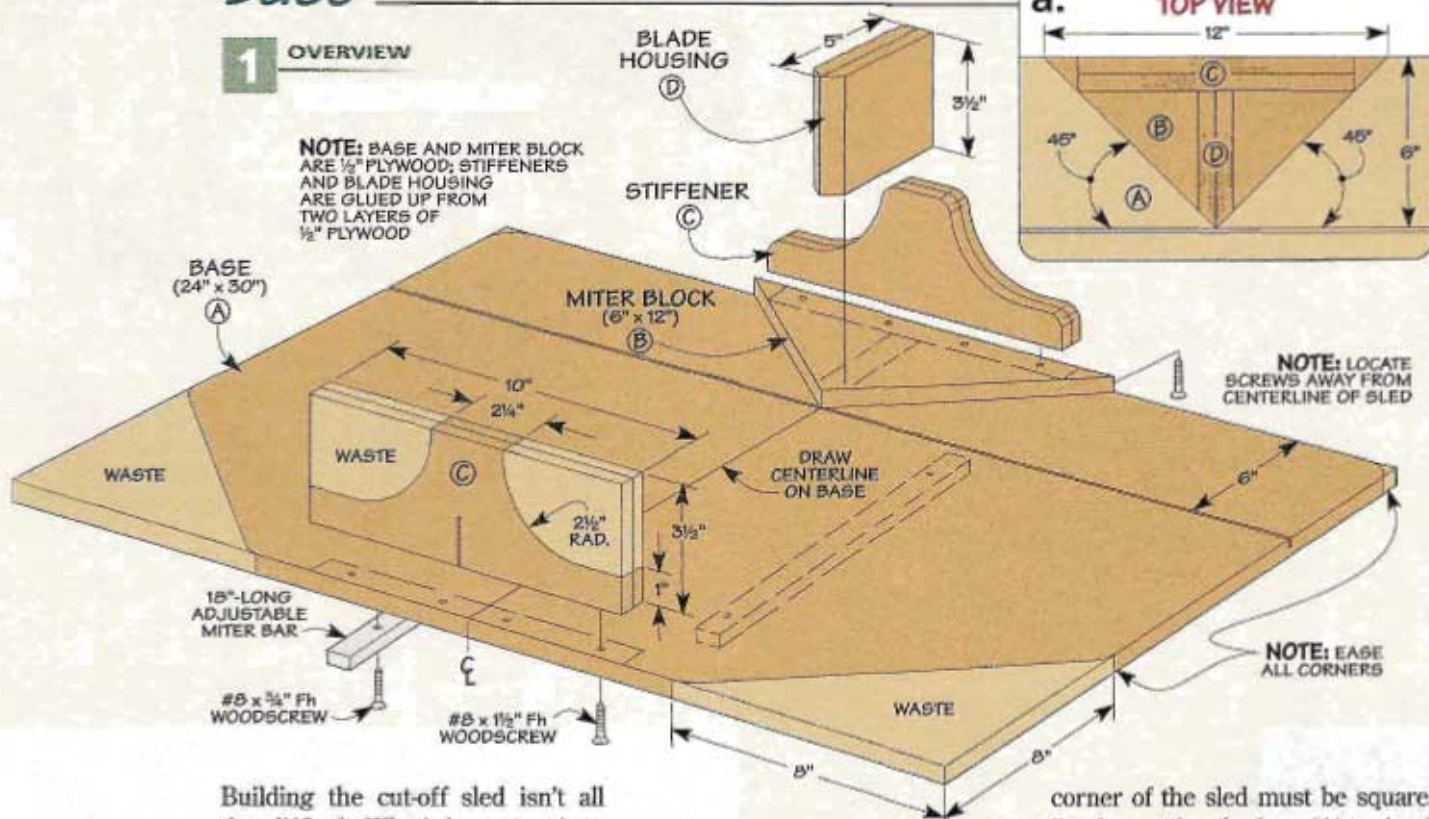

Building the cut-off sled isn't all that difficult. What's important is to build the accuracy into the sled as you go. So before you get started, it's worthwhile to take some time up front getting the base set up so using the sled is automatic later.

First, the saw blade, miter slots, and rip fence need to be aligned parallel to each other. It's best to consult your owner's manual if you need to make any adjustments. And the other thing to keep in mind is that one

corner of the base of the cut-off sled must be cut perfectly square. This way, you can rest assured that once you complete the sled, the fences will be perfectly square to the blade.

MAKE THE SLED BASE

The base of the sled starts out as a rectangular piece of 1/2" plywood, as shown in Figure 1 above. (I used Baltic birch.) As I mentioned, one

corner of the sled must be square. So after cutting the base (A) to size, I checked the corners with a framing square and then marked one corner to use as a reference, as in Figure 2.

The next step is to cut a shallow kerf across the back edge of the base (Figures 2 and 2a). This kerf locks the fences in place — whether you're making a 90° or a 45° cut.

ADD THE BASE SUPPORTS

Once you use the sled for the first time, you'll almost cut the base in two. So the next thing to do is add supports to hold the sled together during a cut. To help position the supports, it's a good idea to mark a centerline on the sled.

Miter Block – The first support to add is the *miter block* (B) you see in Figure 1. This triangular piece of plywood acts as a stop to position the fences on the sled. What's important here is to cut the block accurately so once it's glued in place it's flush along the back edge of the base and forms 45° angles on each side.

Vertical Stiffeners – To add additional support along the back edge of the sled, as well as the front,

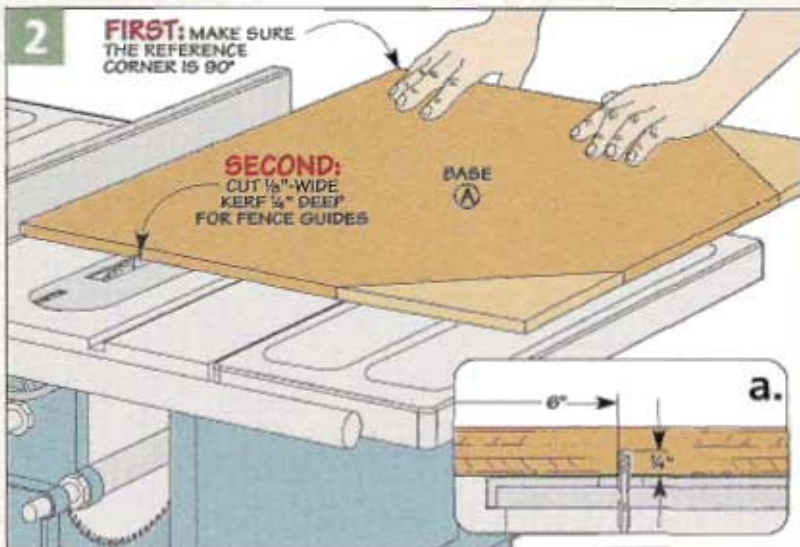

I added a pair of vertical stiffeners. As you can see in Figure 1, the stiffeners (C) are glued up from two pieces of 1/2" plywood. Once you've cut them to shape on the band saw (or with a jig saw), glue and screw them in place so they're flush with the front and back edges of the sled.

Blade Housing - There's one last piece to add to the base of the sled. And that's a housing for the blade. This prevents the blade from being exposed at the end of the cut.

Here again, the housing (D) is made by gluing up a couple layers of plywood. After shaping the leading edge to match the front of the miter block, the housing is glued to both the block and rear vertical support, as depicted in Figure 1a.

GUIDE IT STRAIGHT

Now all that's left to do is add the runners that guide the sled during use and then shape the sled.

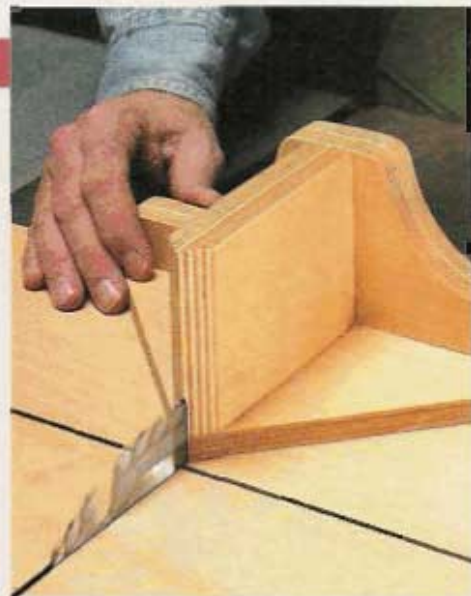
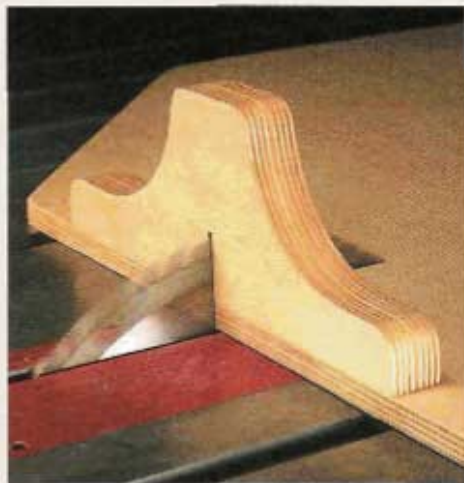

▲ **Cutting a Kerf in the Sled.** Once the sled is complete, you'll need to cut a kerf. To do this, raise the blade about 1 1/2". Next, push the sled through the blade (left) and complete the kerf by sliding the sled until the blade is "buried" half way into the blade housing (right).

To avoid the problems of wood runners sticking due to changes in humidity, I used metal runners on the bottom of the sled, as in Figures 1 and 3. (For more on the runners I used, refer to Sources on page 35.)

There are two things to keep in mind when you attach them. First, you need to locate them accurately. And second, you need to hold them in place while you screw them down.

To locate them, I used the miter slots. Slip the runners in the slot so they set 3" back from the back edge (Figure 3). Note: The margin photo shows a simple way to raise the runners to ensure they make contact with the bottom of the sled.

A few pieces of carpet tape on the top of the runners will allow you to "stick" the runners to the base. To do this, position the rip fence so that once you butt the edge of the base against the fence, the centerline on the sled is positioned directly over the blade.

Next, lower the base like you see in Figure 3 so the front edge aligns with the back edge of the saw table. After you press the base firmly against the runners, you can lift the base off the saw table and flip it over to screw the runners down.

Shape the Edges - Once the runners were screwed in place, I used a jig saw to remove the waste at the front corners of the sled. Then, I sanded the edges and eased all the outside corners, as in Figure 1.

Finally, you're ready to cut a kerf in the sled so you'll know exactly where the cut will be. You can see this in the photos above.



▲ **Give the Runners a "Lift."** A penny at each end of the metal runner raises it just enough to clear the top of the saw table and contact the base of the sled.

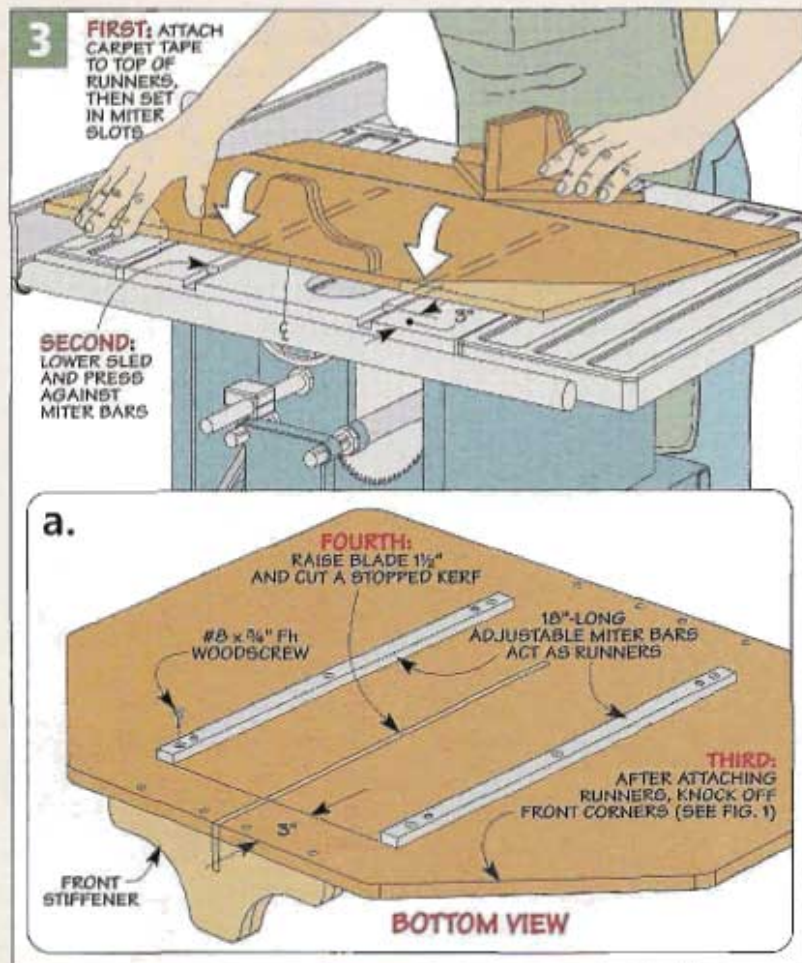

Reversible Fences

With the base complete, you're ready to add the heart of the sled — the reversible fences that make accurate 90° and 45° cuts a snap.

As you can see in the drawing at right, in the main position, the fences butt together to fully support a crosscut. But when you're cutting a miter, the fence slides open to accommodate different width workpieces.

FENCE BASES

Building in the accuracy of the 90° crosscut was taken care of when the base of the cut-off sled was made. The key to building in that same kind of accuracy to get a tight-fitting miter is to make sure that the 45° cut on the fence base (E) is accurate (see Fence Base Detail in Figure 4).

Once you've made two identical bases and double-checked the accuracy of the 45° end, the next step is to cut a long slot in each base. This slot allows you to slide the fences back

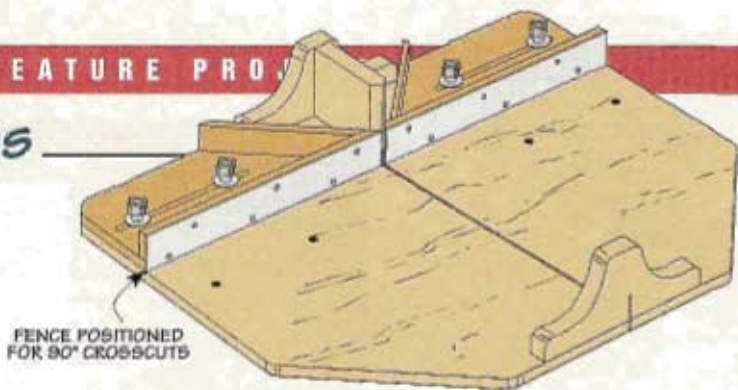

FENCE POSITIONED FOR 90° CROSSCUTS

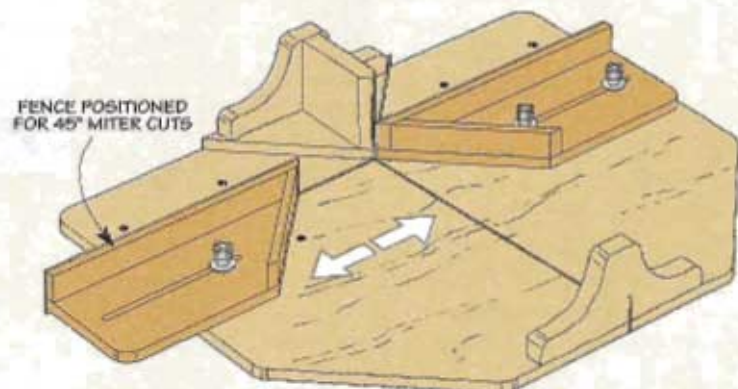

FENCE POSITIONED FOR 45° MITER CUTS

and forth easily, yet lock them down securely once they're in position. Locking the bases in place is handled by a pair of studded knobs that pass through the slot into inserts installed in the base (Figure 4a).

Add the Faces — After completing the slots, you can add the plywood fence faces (F, G) shown in Figure 4. The faces provide solid support for the workpiece whether you're making a miter or crosscut.

The face pieces are glued to the top of the base so they're perfectly

flush with the edges. The last piece to add to the fence is an aluminum guide bar. This bar indexes the fences to the base so they "lock" in accurately no matter what position the fence is used in. You can see how this works in Figure 4a.

The bars are sized in length so they're flush with the ends of the fence (Figure 4b). And they're screwed in place so they're flush with the top of the fence face and extend just below the bottom of the fence base to fit into the kerf cut earlier.

NOTE: FENCE BASE AND FACES ARE 1/2" PLYWOOD

4 OVERVIEW

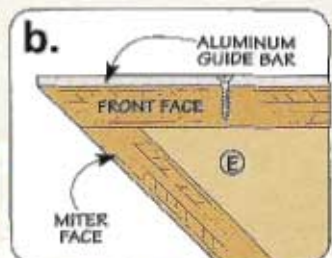
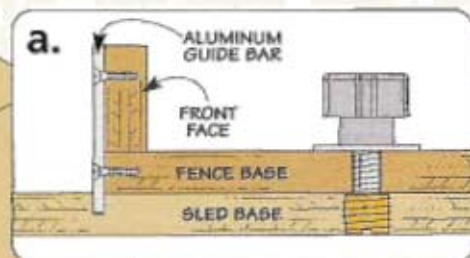
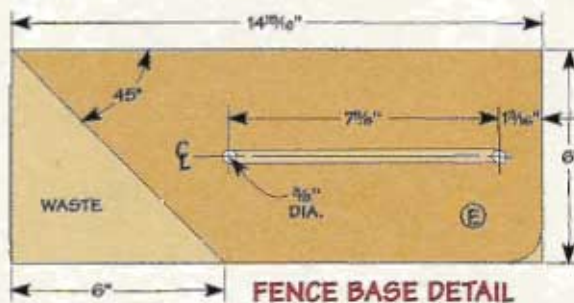
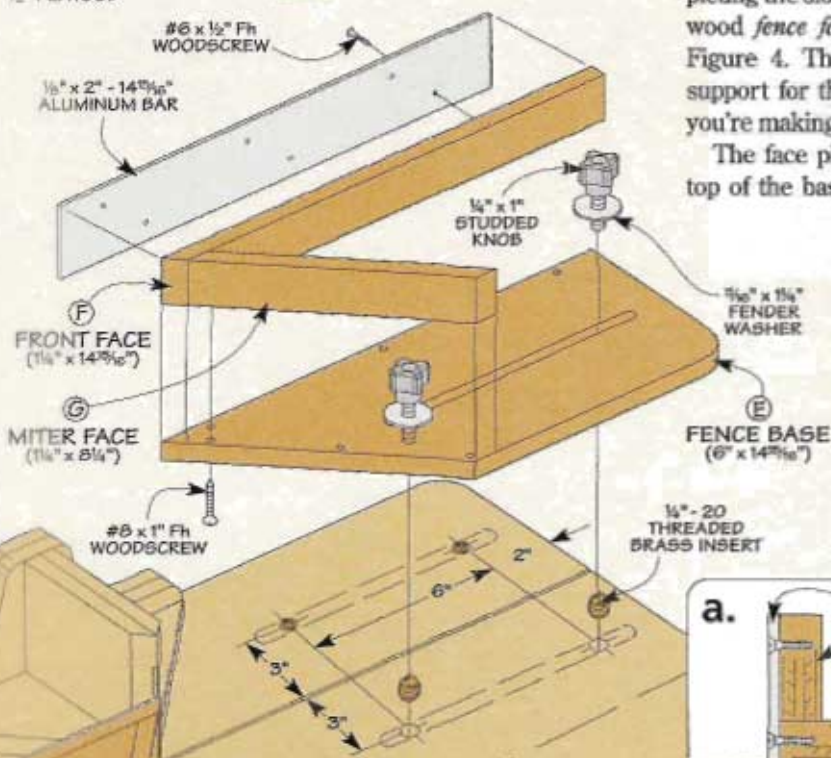

NOTE: SLIDE FENCE IN THE TWO DIFFERENT POSITIONS TO HELP LOCATE INSERTS

Insert Installation Tool

ADD THE INSERTS

All that's left to do is install a set of inserts in the base. These inserts need to align with the slots cut in the fence bases. So I slipped the fences in place to locate the inserts (Figure 4).

Installation Tool - Installing inserts isn't that difficult. It's just a matter of drilling a hole and then driving the insert in straight until it's flush with the surface.

The problem here is that the location of a few of the holes didn't allow me to use my drill press like I usually do. To solve this problem, I made the handy, shop-made insert driver shown in the box at right.

Make the Inserts Flush - I did notice one thing after I drove the inserts in place - they were slightly longer than the thickness of the plywood. So they stuck out past the bottom face a bit. A little filing and sanding takes care of making them flush with the face of the plywood.

Adjusting the Fences - Although there isn't much to working with the fences, the photos below show you how to set them for either a 90° cut or a 45° cut. ▲



Installing a threaded insert in a jig or fixture is a handy way to make the jig easily adjustable. The trick is keeping the insert straight as you're screwing it in place.

Installation Tool - To solve this problem, I made the installation tool shown at right. It's made from a block of 1½"-thick hardwood with a ¾"-deep notch cut in one corner, as illustrated in the drawing at far right.

A counterbored hole is drilled through the notch to hold a bolt and nylon bushing. The through hole is sized to hold the bolt and the counterbore is drilled 1¼" deep to accept the bushing. The bushing holds the hex bolt straight while you tighten it down.

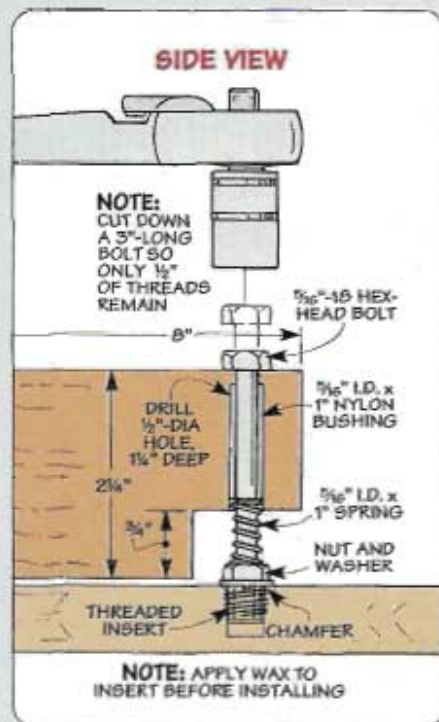

Finally, I added a spring to provide just enough downward pressure to help the threads on the outside of the insert to begin cutting into the wood.

Note: It's a good idea to add a chamfer to the starter hole. This helps prevent the edges of the hole from chipping out.



▲ **Crosscutting.** The reversible fences provide solid support and minimize chipout. Self-adhesive sandpaper attached to the fences improves accuracy by preventing the workpiece from shifting during the cut.



▲ **Miter Cut.** To cut a 45° miter, remove the fences and flip them around like you see above. Here again, the sandpaper prevents the workpiece from creeping during the cut and the tall face makes it easy to get a secure grip.

Sled-Mounted Tenoning Jig

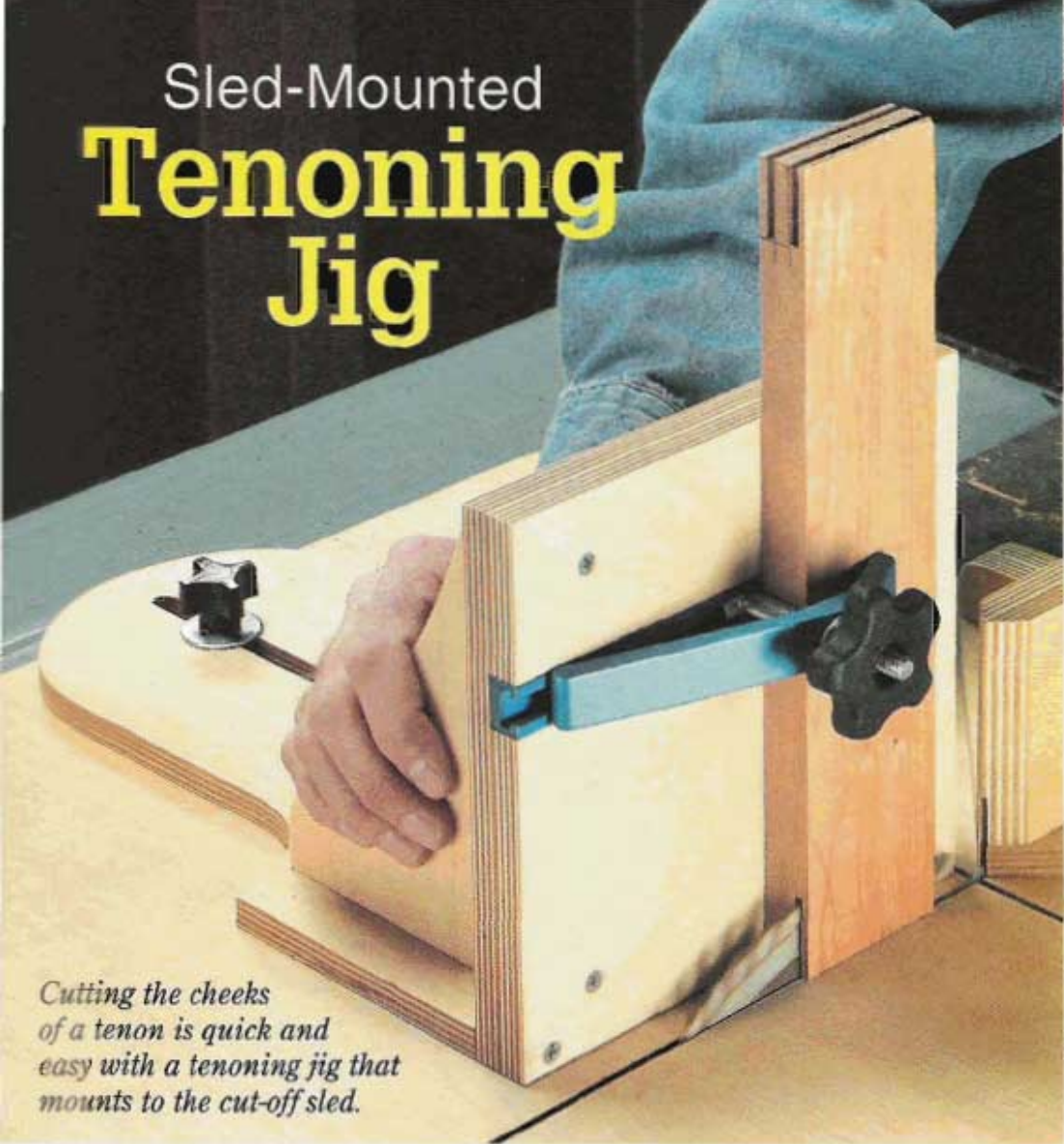

Cutting the cheeks of a tenon is quick and easy with a tenoning jig that mounts to the cut-off sled.

The third part of the 3-in-1 cut-off sled is the tenoning jig shown in the photo at left. Making the tenoning jig only takes a little extra work, but the perfectly smooth tenon cheeks that result are worth the extra effort.

How the Tenoning Jig Works – The tenoning jig fits in the same kerf that the fences slip into and holds the workpiece vertically. Here again, the kerf keeps the jig positioned properly as you slide it towards (or away) from the blade to adjust the thickness of the tenon.

Note: I built my tenoning jig to cut on the right side of the cut-off sled. If you feel more comfortable working from the left, simply build the jig as a mirror image.

Start with the Base – I started by cutting a *base (H)* to the size and shape detailed in Figure 1. Like before, to ensure accurate tenons, make sure the back corner is square. Once that's complete, you can cut the slot that allows you to adjust the jig and vary the thickness of the tenons.

What's important here is that you locate the slot so it aligns with the inserts already installed in the sled base. So just measure from the kerf to

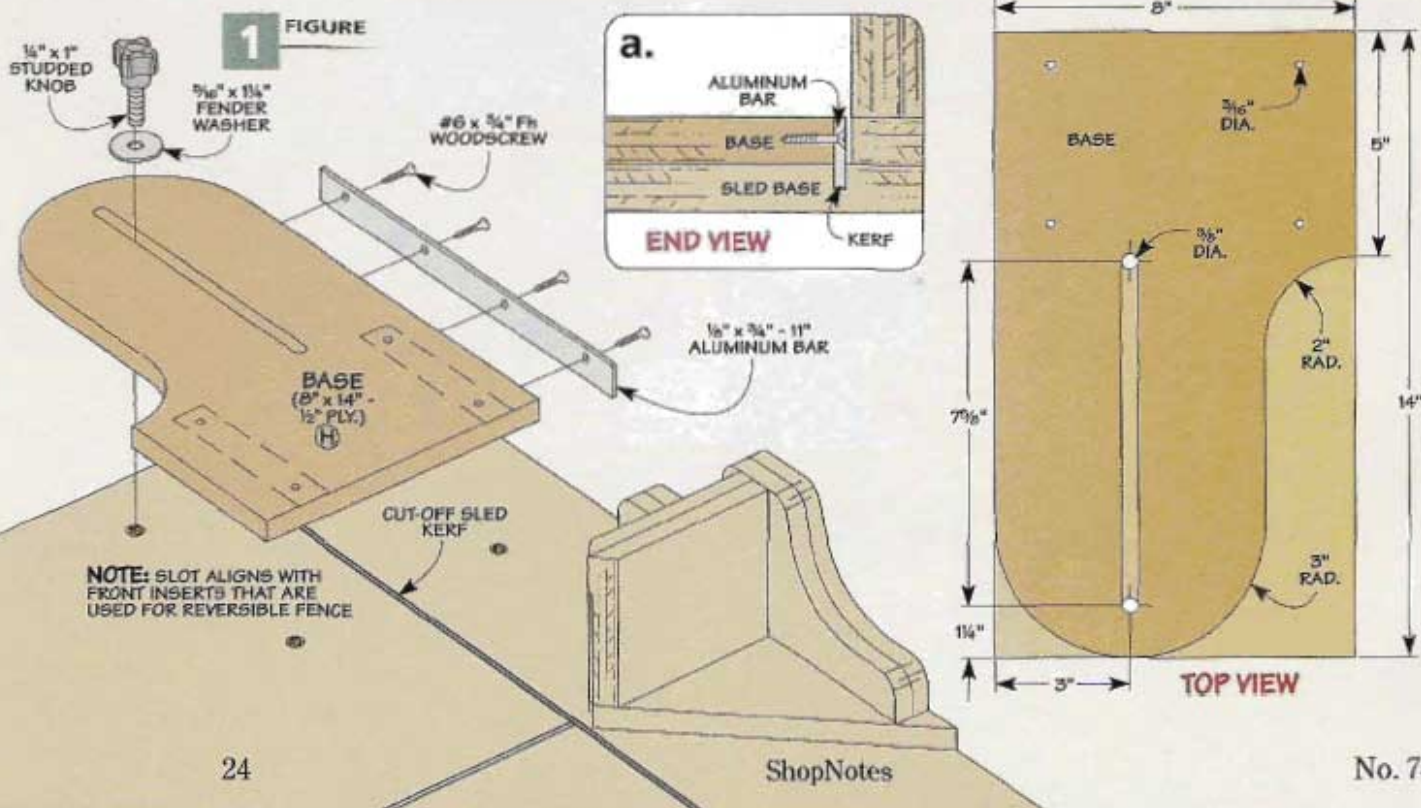

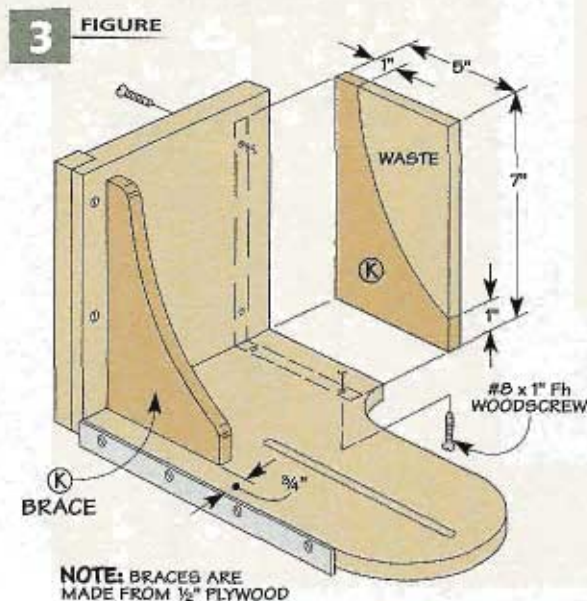
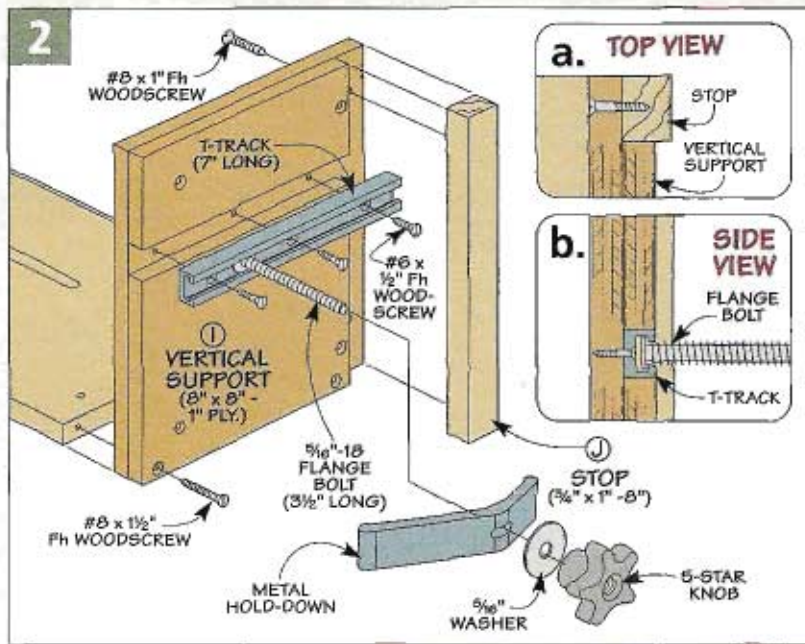

the inserts and locate the center of the slot the same distance in.

Like the fences, the tenoning jig alignment is "locked" in place by adding a small aluminum plate along the back edge of the base (Figure 1a).

Add the Vertical Support – Keeping the workpiece straight up

and down is handled by the vertical support. This support (I) is nothing more than two glued up layers of plywood (Figure 2 above).

Before you screw the support in place, you'll need to make a pair of cuts. The first cut is for a dado that houses a T-track (Figure 2b). The T-

track accepts a flange bolt so you can use a knob and hold-down to secure the workpiece to the jig (Figure 2).

The second cut is a rabbet along the back edge (Figure 2a). This is for a hardwood stop (J) that holds the workpiece in place. The stop is simply screwed to the vertical support so you can replace it easily.

Finally, I added a pair of braces (K) to stiffen the vertical support. Figure 3 shows how the braces are shaped and attached to the jig.

Completing the Tenon

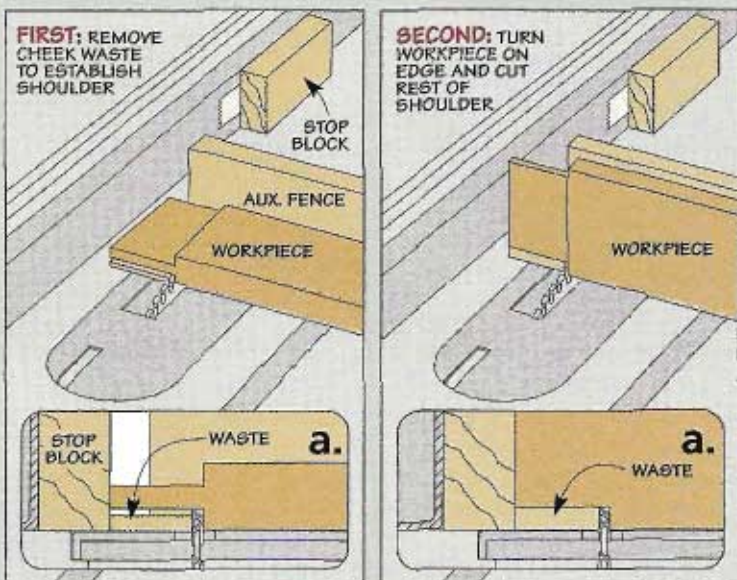

▲ **Tenons.** The tenoning jig makes quick work of cutting the cheeks of a tenon. But to complete the tenon, you'll need to trim off the waste, as in the left drawing. Then you can flip the workpiece on edge and nibble away the remaining waste to form the rest of the shoulders.

USING THE TENONING JIG

There isn't much to using the tenoning jig. Start by removing the right fence and slipping the tenoning jig into the kerf.

To locate the cut, clamp a workpiece in place and then slide the jig towards (or away) from the saw blade until the blade lines up with the desired location of the cheek. Finally, tighten the knobs to lock the tenoning jig to the base.

After raising the blade to match the length of the tenon, make a pass over the saw blade like you see on the opposite page. To cut the other cheek, flip the workpiece around and make a second pass.

To complete the tenon, you'll need to form the shoulders. You can see how to do this in the box at left. 🛠️

Extendable Drill Press Table

Here's a drill press table that "grows" to handle long workpieces.



It's no secret that the tables on most drill presses are pitifully small when it comes to woodworking. The solution, of course, is to build an auxiliary table. But this just leads you to a new problem. You want the table to be big enough to handle long workpieces, but at the same time, you don't want it to take up too much space. The drill press table you see in the photo above does both.

This drill press table works a lot like a dining room extension table. The ends of the table slide on steel rails so you can instantly make the table wider. But instead of adding extra leaves (like you would on a dining table), the

workpiece simply spans the opening as shown above. Most of the time, you can use the drill press table with the ends pushed all the way in. But when you need a little extra support for a longer workpiece, all you have to do is pull out one (or both) of the ends.

In addition to the expandable ends, there are a couple of other features worth mentioning. First, a pair of T-tracks in the top of the table are used to hold a simple, adjustable fence. And second, there's a replaceable insert in the center of the hardboard top so that you can renew the surface periodically when it gets chewed up.

EXPLODED VIEW
OVERALL DIMENSIONS:
 10"D x 29 3/4"W x 4 1/4"H
 (with ends closed)

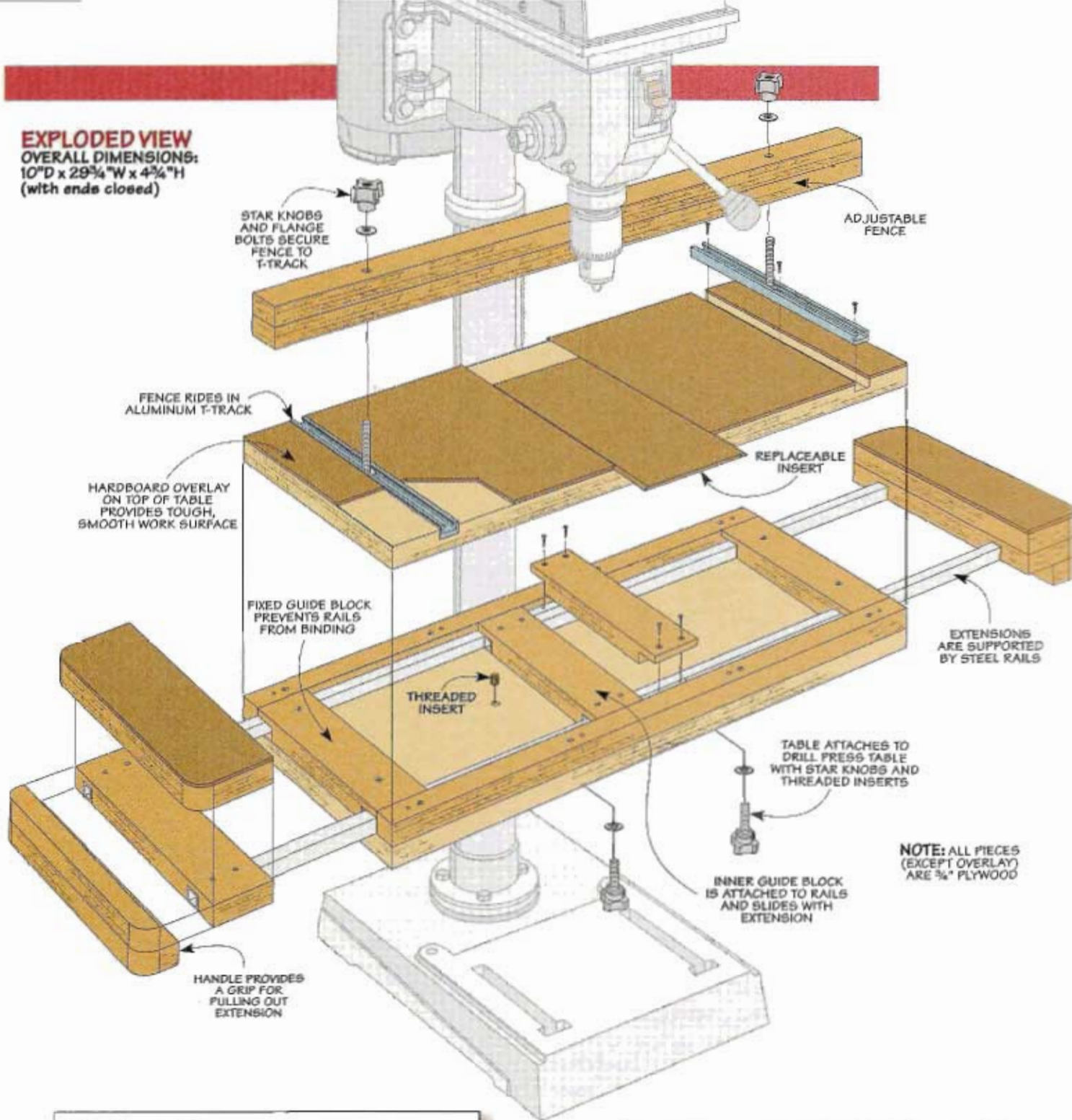

Materials

A Base (1)	10 x 23 3/4 - 3/4 Plywood
B Spacers (2)	1 x 23 3/4 - 3/4 Plywood
C Guide Blocks (4)	8 x 2 - 3/4 Plywood
D Extension Bases (2)	10 x 2 1/4 - 3/4 Plywood
E Top (1)	10 x 23 3/4 - 3/4 Plywood
F Top Overlays (2)	9 7/8 x 10 - 1/4 Hardboard
G Insert (1)	4 1/2 x 10 - 1/4 Hardboard
H Extension Caps (2)	10 x 3 1/4 - 3/4 Plywood
I Handles (2)	10 x 1 1/2 - 3/4 Plywood
J Extension Tops (2)	10 x 3 - 3/4 Plywood
K Extension Overlays (2)	10 x 3 - 1/4 Hardboard
L Fence (1)	1 1/2 x 28 - 1/2 Plywood

Hardware

- (12) #8 x 1 1/4" Fh Woodscrews
- (8) #8 x 2" Fh Woodscrews
- (4) 1/2"-Square Steel Tubing (23 3/4" long)
- (16) 8-32 x 3/8" Self-Tapping Machine Screws
- (2) 1/2" x 3/4" Aluminum T-Track (10" long)
- (6) #6 x 1/2" Fh Woodscrews
- (2) 5/16" x 2 1/4" Flange Bolts
- (2) 5/16"-18 Star Knobs
- (2) 5/16"-18 Star Knobs w/1"-long stud
- (2) 5/16"-18 Threaded Inserts
- (4) 5/16" Washers

Base & Extensions

1 OVERVIEW

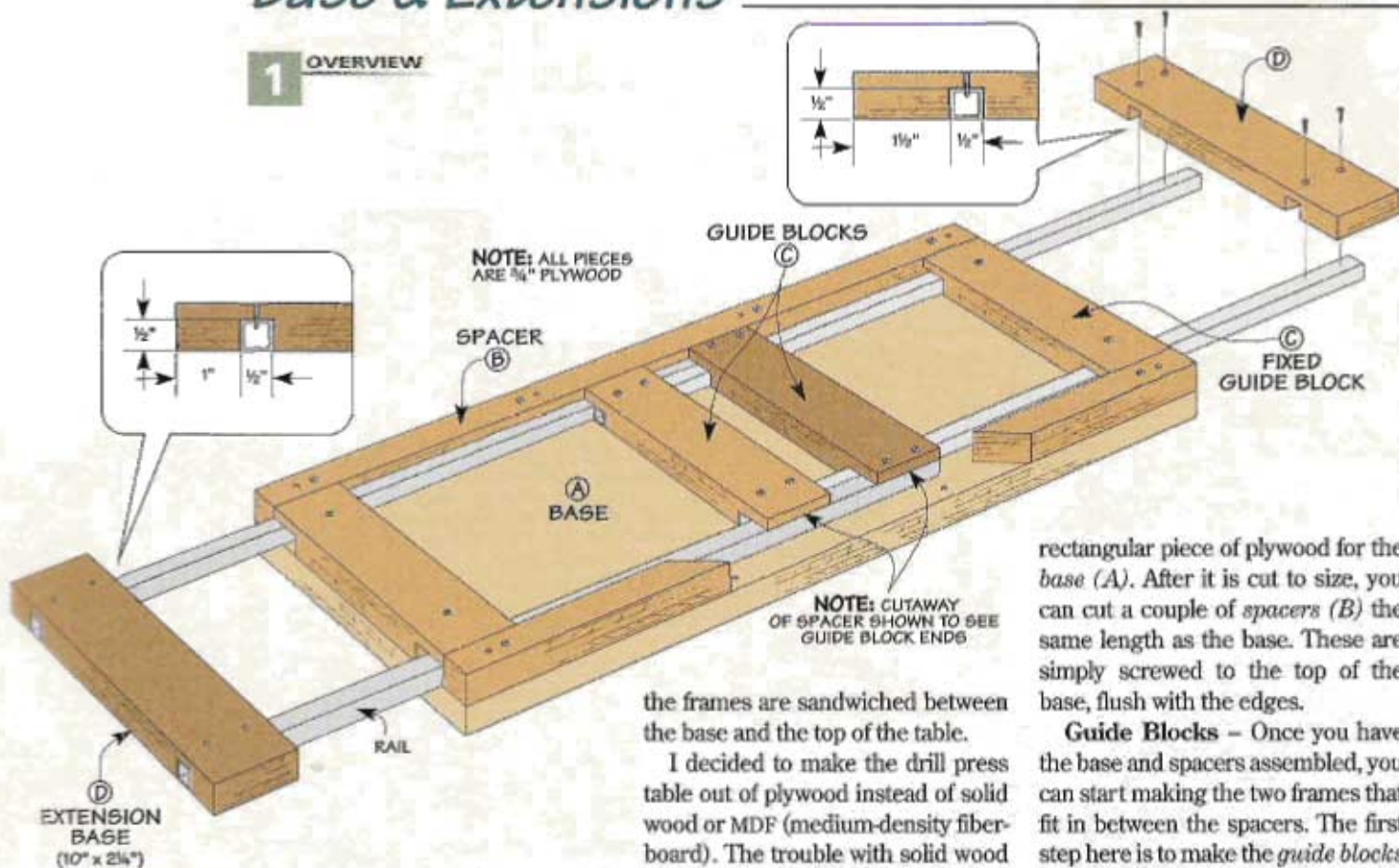

rectangular piece of plywood for the *base* (A). After it is cut to size, you can cut a couple of *spacers* (B) the same length as the base. These are simply screwed to the top of the base, flush with the edges.

Guide Blocks – Once you have the base and spacers assembled, you can start making the two frames that fit in between the spacers. The first step here is to make the *guide blocks* (C). As you see in Figure 1, each block is just a narrow piece of plywood with a rabbet cut at each end to allow it to fit over the steel rails.

Since all four of the guide blocks are identical, I cut them from a single, extra-wide blank. After cutting a rabbet on each end of the blank, the individual blocks are ripped to width (Figures 2 and 3).

the frames are sandwiched between the base and the top of the table.

I decided to make the drill press table out of plywood instead of solid wood or MDF (medium-density fiberboard). The trouble with solid wood is that it tends to expand and contract with changes in humidity, and this would create all sorts of problems with the moving parts of this project. And I ruled out MDF because it would make the table too heavy and difficult to raise or lower once it was on the drill press.

Base – To build the drill press table, I started off by cutting out a

If you take a look at Figure 1, you'll get a good idea of how the drill press table works. There are two rectangular "frames" that slide back and forth inside the table. Each frame is made up of a pair of square steel rails and a couple of pieces of plywood. The frames interlock inside the table so that the rails of one frame slide right past the rails of the other. Then

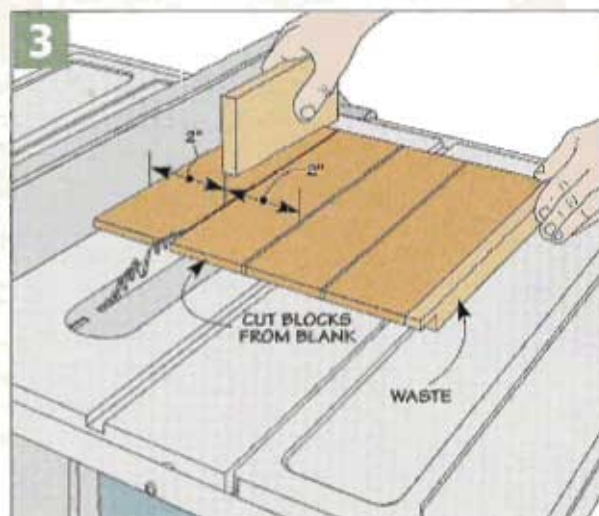
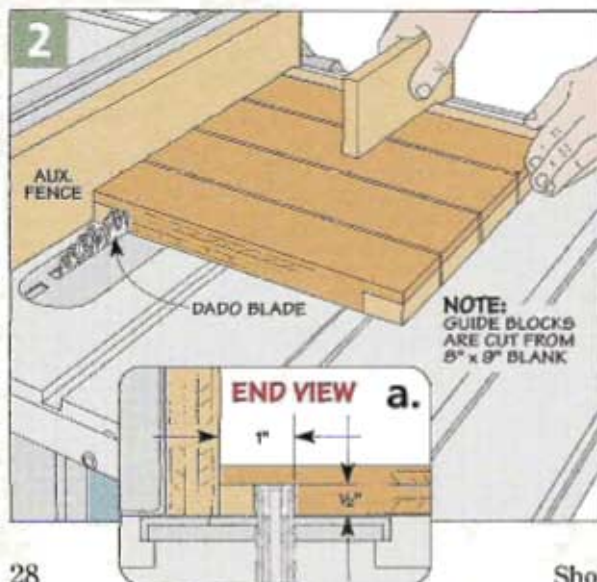

There's just one thing to be aware of here. When you're sizing the rabbets, make sure that they are wide enough to allow the block to fit over the steel rails with enough clearance so that the rails will still have room to slide freely. You don't want a sloppy fit, but if you make the rabbets too tight, you'll have a hard time pulling out the extensions.

If you look at Figure 1 again, you can see that there is a guide block attached to the end of each pair of rails. The other two guide blocks are attached in a fixed position directly to the base. You can go ahead and screw these fixed guide blocks to the base at this time, making sure that the blocks are flush with the ends of the base.

Rails - Before you can attach the remaining two guide blocks, you'll have to make the rails. I cut these to length from some square steel tubing. Then to attach the guide blocks, I slid both pairs of rails into the base and positioned the guide blocks so they were flush with the ends of the rails. With the guide blocks clamped in place, you can drill countersunk screw holes in the blocks and rails. Then simply screw the blocks to the rails with some self-tapping machine screws.

Extensions - With the rails and guide blocks in place, the next step is to add the extensions to the ends of the rails. Like the main part of the

4 FIGURE

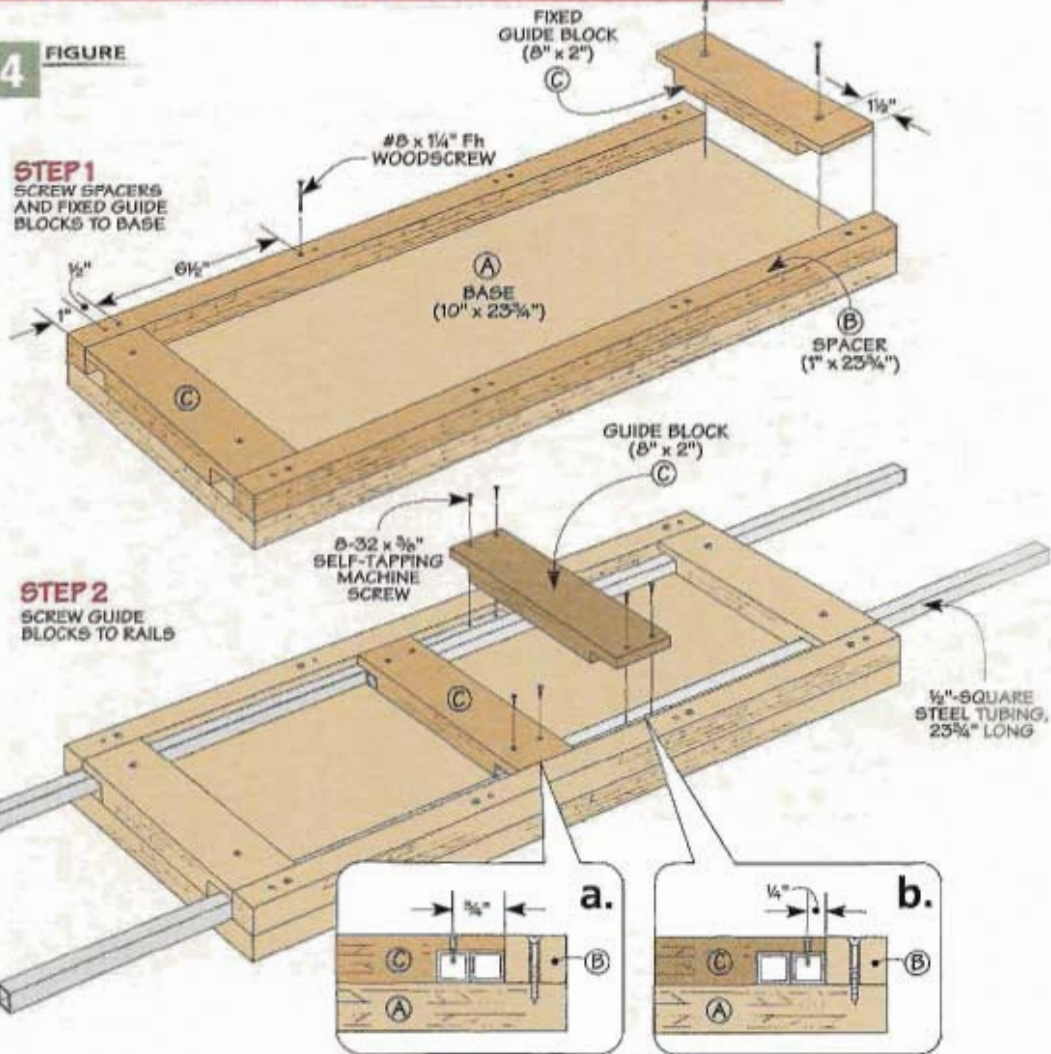

table, the extensions are made up of several layers. But for now, all you need to do is make a pair of extension bases (D) to fit over the rails. These are simply cut from plywood to match the width (depth) of the

base of the table. Then a pair of dadoes is cut in each extension base to allow it to fit over the rails. But if you take a look at the details in Figure 1, you'll see that the dadoes are in different locations for each base. Finally, you can attach the extension bases to the ends of the rails by clamping them in place and drilling holes for some screws.

Threaded Inserts - Before moving on to adding a top, there's one thing to take care of. I drilled a couple of holes in the underside of the base and added some threaded inserts. These will be used later on to mount the table to your drill press. Installing the inserts is simply a matter of positioning the base on the table of your drill press and marking out the locations for the inserts. (Depending on your drill press, you may need two or four inserts.)

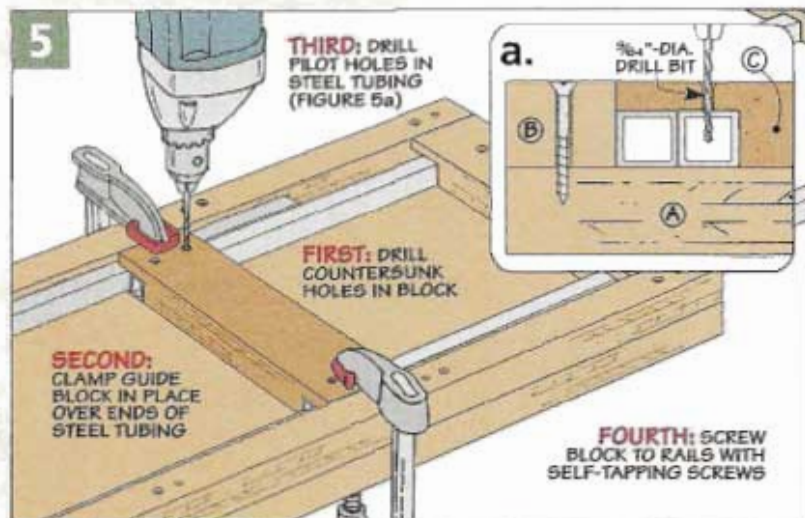

Top & Fence

6 FIGURE

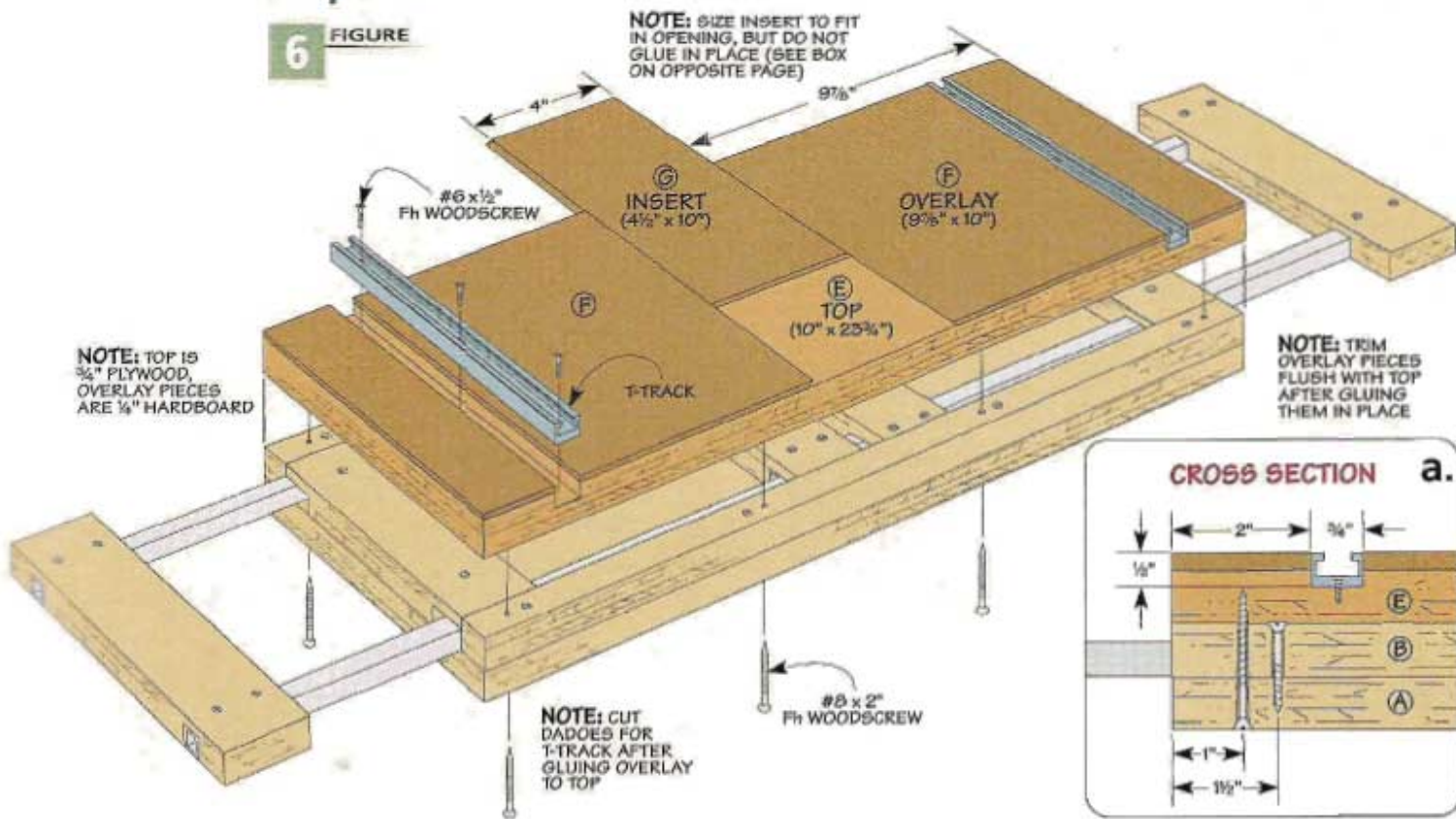

With the lower portion of the table complete, you can now turn your attention to adding the top to the table. The top is made up of two layers — a plywood panel with a hardboard overlay. This provides a tough, long-lasting worksurface.

To make the top, start by cutting a plywood top panel (E) to size to match the base of the table. Once this is done, you can add the hardboard overlay. But if you take a look at Figure 6, you'll see that the overlay is made up of three separate pieces. That's because the center piece is actually a replaceable insert. The edges of the insert are beveled to allow it to slide into a dovetail-shaped opening in the top. This way, you can replace the insert as it gets chewed up by drill bits.

I cut the left and right sides of the overlay first, making them slightly oversized and beveling the inside edges. Then when it came to gluing them down to the top panel, I used the simple procedure that you see in the box on the opposite page.

After flush trimming the overlay pieces with the plywood top, you can cut an insert to fit in the opening, just as you see in the drawing above.

T-Tracks – There's one more thing to do before attaching the top to the rest of the table. And that is to add a couple of aluminum T-tracks for a fence that will be made later. The T-tracks fit into dadoes cut in the top of the table. I cut these dadoes on the table saw, but you

could also make them on a router table. After the dadoes are cut, all you have to do is cut the T-track to length and screw it in place.

Attaching the Top – The top is simply screwed in place from below. I didn't use any glue here in case I ever need to make any adjustments to the fit of the rails or guide blocks.

Extensions – Like the main section of the table, the extensions will also be covered with a layer of



plywood and hardboard. But first there are a couple of extra pieces to make. To start with, I covered the exposed ends of the rails by adding an *extension cap (H)* at each end, as shown in Figure 7. Each cap is nothing more than a narrow strip of plywood that is glued in place to the end of the extension base.

Handle – In addition to the cap, I also added a slightly wider block of plywood to the underside of each extension to serve as a handle to make it easier to pull out the extension. These *handles (I)* are simply glued in place flush with the edge of the cap.

Extension Tops – With the caps and handles in place, you can go ahead and make the extension tops. Each *top (J)* is cut to size from 3/4" plywood. Then a pair of *overlays (K)* are cut from 1/4" hardboard. These should be cut slightly larger than the extension tops so that you can flush trim them to size after they are glued in place. Once this is done, the extension tops can be glued to the extension bases.

The last step to complete the extensions is to round off the corners. I did this by drawing a radius

7 FIGURE

FIRST: GLUE CAP AND HANDLE TO EXTENSION BASE

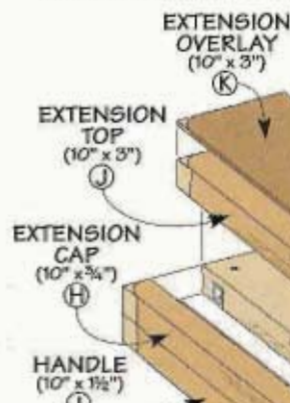

NOTE: CUT 3/4" RADIUS ON OUTSIDE CORNERS AFTER GLUE UP

NOTE: FENCE IS GLUED UP OUT OF TWO LAYERS OF 3/4" PLYWOOD

SECOND: GLUE HARDBOARD OVERLAY TO EXTENSION TOP AND TRIM FLUSH

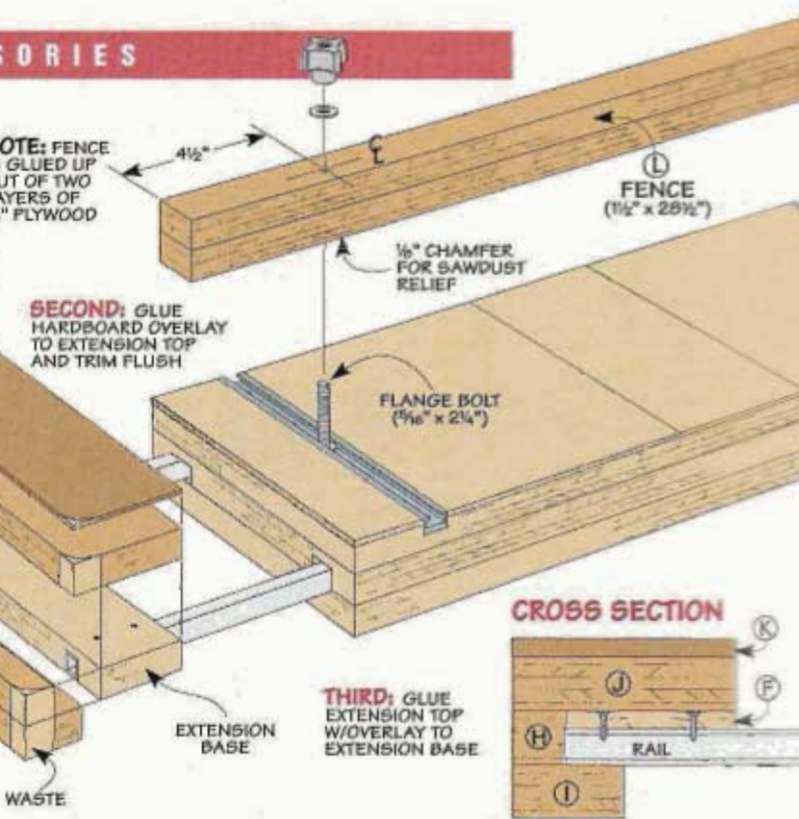

THIRD: GLUE EXTENSION TOP W/OVERLAY TO EXTENSION BASE

CROSS SECTION

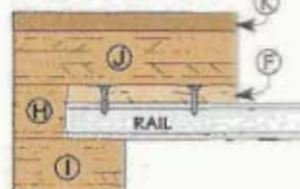

on each corner and removing most of the waste on the band saw. Then I sanded each corner smooth.

Fence – All that remains is to add a fence. There's nothing fancy here — the *fence (L)* is just two strips of plywood glued together. A chamfer is routed along the bottom edge of the fence for sawdust relief. Then

after drilling a couple of holes in the fence, it gets attached to the table with a pair of star knobs, washers, and flange bolts (Figure 7).

With the fence completed, you can mount the table to your drill press using some star knobs, washers, and the threaded inserts you installed earlier.

Glue-Up Tip

FIRST: CENTER AND CLAMP 3/4" PLYWOOD SPACER TO TOP

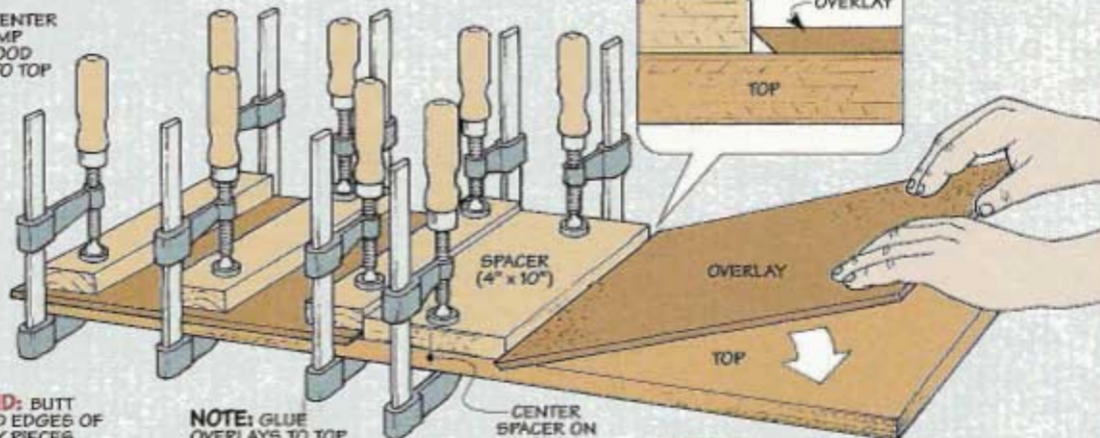

SECOND: BUTT BEVELED EDGES OF OVERLAY PIECES AGAINST SPACER AND GLUE THEM DOWN TO TOP

NOTE: GLUE OVERLAYS TO TOP WITH BEVELED EDGES FACING DOWN (SEE DETAIL)

THIRD: TRIM OVERLAY FLUSH TO TOP WITH ROUTER

Gluing Down the Overlays. The trick to gluing the overlays to the top of the table is to make sure that the beveled edges are parallel so that the insert

will slide smoothly into the opening. To do this, I clamped a plywood spacer to the top and butted the overlays against it while gluing them in place.

It's something that none of us likes to think about. But you can save yourself future headaches by making preparations today.

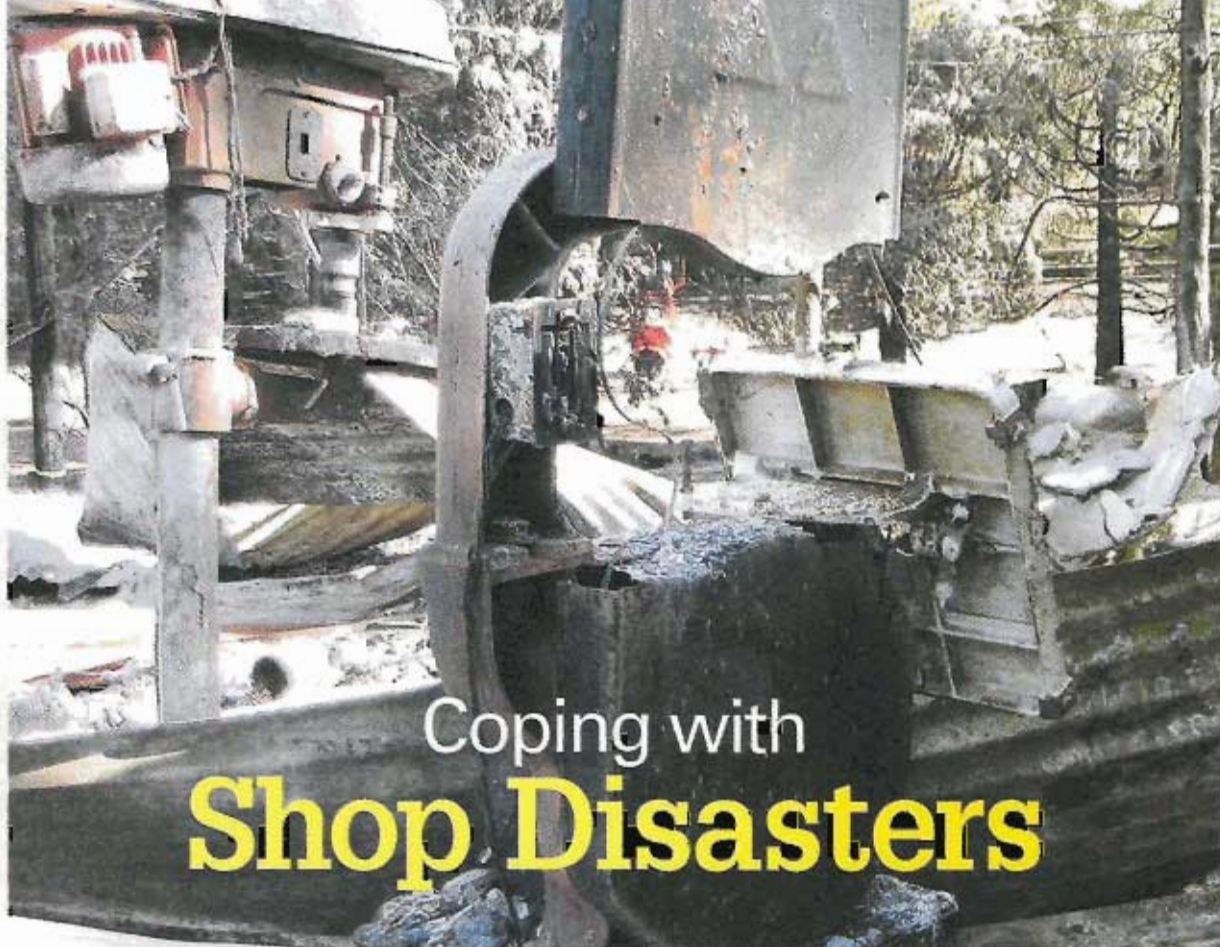

Coping with Shop Disasters

Photo courtesy of Maria Jayne Goodson

John Pierce was one of the unfortunate ones. In October of 2003, when wildfires swept through southern California, John lost his entire house and everything in it, including a well-equipped woodworking shop. All that remained of the shop after the fire were the burned-out skeletons of power tools, standing silent among the rubble (see the photo above). To make matters even worse, John later learned that he didn't have enough insur-

ance to cover all of the losses he suffered as a result of the fire.

You may never have to face a catastrophe of this magnitude, but there are plenty of woodworkers who have experienced smaller-scale disasters in their shops. Whether it's a burglary, a shop fire, or something as simple as a broken water pipe, shop disasters are more common than you might think.

Fortunately, there are a few simple steps you can take to pre-

vent a shop disaster or make things a whole lot easier if you're ever unlucky enough to experience one.

Prevention – No doubt you've heard the expression that an ounce of prevention is worth a pound of cure. This is good advice, and there are some obvious safeguards you can take. A fire extinguisher is a must-have in every shop. For a home shop, a good choice is a 10-lb. extinguisher rated for all classes of fires (combustible solids, flammable liquids, and electrical fires).

If you do a lot of finishing, you might want to invest in an oily waste disposal can. These waste receptacles are built out of heavy-gauge steel and are designed to prevent fire from spreading in the event of a spontaneous combustion of finishing rags. You can purchase one for around \$50.

When it comes to theft, the fact is that if someone wants to break into your shop bad enough, they'll probably find a way. But you can make things as difficult as possible for would-be thieves by making sure all doors and windows to your shop are



▲ **Fire Prevention.** A metal can provides a safe place to dispose of oily waste rags. The can will contain the fire if the rags should spontaneously combust. Locate your fire extinguisher in an easy-to-reach spot.

locked and secure. A burglar alarm will provide another level of security.

Inventory – One of the hardest things about dealing with a shop loss is simply trying to remember everything you had. So one of the best things you can do to protect your shop is to make a detailed inventory. Include the brand and model number of each tool, and the purchase date and price if you know it. If you have receipts, so much the better. There are many inexpensive computer programs that allow you to create a detailed inventory of all the items in your shop or home (see box in margin at right). When you've completed your inventory, store it in a safe place, away from your shop.

To go along with that inventory, you may want to take photos or even a video of the contents of your shop. The more documentation you can give to an insurance claims adjuster, the easier the process will be. This is especially true if you have any unusual shop tools, or multiples of a tool. Otherwise, you might have a hard time convincing the claims adjuster that you *really* did own five different routers.

Insurance – Despite taking all the precautions, a shop disaster may still occur. With this in mind, it's important to make sure that your shop is adequately insured. The good news is that in most cases your homeowner's or renter's insurance

policy will cover your shop as well. In the event of a disaster, the insurance company will view the contents of your shop just like any of your other belongings. But there are a few additional points to be aware of.

Amount – First, make certain that the amount of insurance you are carrying is adequate to cover the value of your belongings, including your shop. Most homeowner's policies cover contents (personal belongings) up to a certain amount. Depending on how much you have invested in your shop, and the value of your other belongings, you may want to talk to your insurance agent about purchasing additional insurance.

Coverage Type – In addition to the amount of coverage you have, you should also inquire about the type of coverage. Some policies only cover the depreciated value of your belongings, while others provide you with the actual replacement cost. Replacement cost insurance is typically more expensive, but in the event of a disaster, you won't be faced with the prospect of receiving \$50 for your ten-year-old drill press, and then finding out that a new one is going to cost you \$350.



▲ **Documentation.** Photos, video, digital images, and an inventory can be invaluable in determining your losses following a disaster.

Shop Location – When it comes to insurance coverage, the location of your shop is also important. In most cases, if your shop is in the basement, garage, or spare room of your house, it is covered under your homeowner's insurance. If you have a separate building on your property for your workshop, then you should double check to make sure that your policy covers it. Often, the contents of the shop will be covered, but the shop structure may require an insurance rider or its own policy.

One other caution. If your shop is used for business purposes, even on only a part-time basis, chances are your standard homeowner's insurance will not cover you in the event of a disaster. You'll probably need a separate policy specifically for businesses. Again, it's best to discuss this with your agent.

Finally, it's a good idea to read your policy carefully to see what kinds of losses are covered. Fire and theft are usually covered, but other disasters like floods or earthquakes may not be. The time to learn about this is before disaster strikes, not after. 📌

10 Tips for Safeguarding your Shop

1. Allow finishing rays and towels to completely dry out before disposing of them.
2. Keep a fire extinguisher in an easy-to-reach spot in your shop.
3. Don't allow sawdust or wood scraps to pile up.
4. Don't apply flammable finishes or adhesives near an open flame or heat source.
5. If you use a heater or stove in your shop, keep the area around it clear and free from debris.
6. Don't overload electrical circuits in your shop.
7. If you live in an area at high risk for crime, consider installing an alarm system in your shop.
8. Periodically review your insurance policy with your agent to make sure you are adequately covered.
9. Make an inventory of everything in your shop. Keep it, along with any tool receipts, in a safe place off-site.
10. Take photos or videos of each area of your shop so you can spot items that are missing in the event of a break-in.

Inventory Software

My Stuff - \$19.95
Home Assistant Plus for Inventory - \$39.95
Home Inventory 4 - \$19.95
Everything I Own - \$14.95
MeasLess Home Inventory - \$39.95
SAFE Home Inventory - \$49.95
DoInventory - \$19.95

The Fein Shop Vacuum

This is one shop vacuum you won't mind turning on. It's powerful, but whisper quiet.

One of the quickest ways to clean up a shop is to turn on a shop vacuum and start sucking up the dust and chips. Unfortunately, in our shop, it often ended up forcing everyone to head for the door to avoid the ear-splitting noise.

Well, that all changed when we added a *Fein Turbo Vac II* shop vacuum (Model 9-55-13) to our shop. It's normally hooked up to the router table, but we also use it whenever a job requires a lot of sanding (which is almost every day).

So what makes a *Fein Turbo Vac* so different?

Whisper Quiet – As I mentioned before, a shop vacuum isn't something everyone likes to hang around and listen to. So it's quite interesting to see the look on someone's face when the *Fein* powers up. The *Fein* is so quiet, they're not quite sure if it's actually running.

Plus, you can have a normal conversation while it's on. One of the guys even placed his hand over the end of the hose to be sure it was working. (He also found out how powerful it was.) I checked the decibel reading and the *Fein* is even quieter than the floor vacuum I use at home.



◀ Attachments.

A variety of high-quality attachments, like this dual-purpose head, allow you to use the *Fein* anywhere you need a vacuum.

Automatic Operation – A big advantage the *Fein* has over many other shop vacuums is automatic operation. With most shop vacuums, you have the hassle of having to remember to turn on the vacuum before you start using a power tool.

With the *Fein*, simply plug your tool into the vacuum and switch the power controls to "automatic." When you turn on your power tool, the vacuum turns on automatically (photo at left). And once you turn the tool off, the vacuum runs a bit longer to clear any sawdust or chips from the hose before turning itself off.

Accessories – Although the standard vacuum allows you to do a lot, you can increase the versatility of the *Fein* by adding an accessory kit. The kit has the usual attachments, but the vacuum head (photo above) is especially nice. It features metal extension tubes and an adjustable head you can use on both hard surface floors and carpeted or matted areas.

Cost & Availability – You probably won't find the *Fein Turbo Vac II* at your local hardware store. But you can order it by mail (see margin on opposite page).

Just don't be surprised by the price (about \$220). It reflects the quality built into the vacuum and accessories. An accessory kit (\$70) and pleated filters (1 micron, \$33; HEPA, \$75) will run you extra.

But for the quietest shop vacuum I've ever used, it's well worth it. 🐶



▲ The "Brains." Switched to auto mode, the vacuum powers up automatically when you turn on a tool.



▲ Dust-Free. When hooked up to a major dust producer like this sander, the *Fein* shop vacuum virtually eliminates dust.

▶ A Long Reach. A long cord and crush-proof hose means you can reach 35' from any outlet to get at dust and chips.



Sources

3-in-1 Cut-Off Sled

■ The table saw cut-off sled on page 18 requires a handful of hardware that you'll be able to find at the local hardware store or home center — screws and aluminum stock. That's all you'll need unless you plan to use an adjustable miter bar for the runners like we did. The two 18"-long runners

(#36786) we used came from *Rockler*.

While you're at it, you might want to order all the hardware you'll need to complete the tenoning jig. You'll need to ask for a metal hold-down (#21912), a flange bolt (#34771), a 5-star knob (#23812), and a piece of T-track (2'-long section, #21739).

Drill Press Table

■ Like the other projects in this issue, most of the supplies for the drill press table are typical hardware store items— woodscrews, washers, and square steel tubing. But there are a couple items you might find easier to mail-order.

T-Track – To make the fence easily adjustable, we installed T-track in the top of the table. The T-track we used came from *Rockler* (#21739), but there are a few other sources listed in the margin at right.

Knobs – To lock the fence to the table, you'll need a pair of knobs and flange bolts. Check the margin for sources. Also, you'll need threaded inserts and studded knobs to mount the table to your drill press. (My table required two sets.)

Steel Tubing – If you have trouble locating the 1/2"-square steel tubing, you can find it through *McMaster-Carr*. You will need two 6'-long pieces of part number 6527K11.

Hinge Mortising Jig

■ If you're resourceful enough, you can find all the hardware required for the hinge mortising jig (page 6) at a local hardware store or home center.

But if you have trouble locating the knobs, you can get them from *Rockler*. You'll need three of the 1" round studded knobs (#34238). *Rockler*

also has threaded inserts if you need some (#33183).

If you can't find aluminum stock locally, give *Reid Tool* a call and ask for MES-658 (3'-long piece).

Finally, to make the clear plastic auxiliary base, you can order a 12" x 12" piece of 3/8"-thick plastic (#16L71) from *Woodcraft* (see margin).

Online Extras

■ If you don't have access to the internet, we'd be happy to mail a copy of the hardware storage cabinet cutting diagram and hardware list to you. All you need to do is send a self-

addressed, stamped #10 envelope to:

ShopNotes #74
Online Extras
P. O. Box 842
Des Moines, IA 50304

Hardware Storage Cabinet

■ A few nails and screws are all it takes to assemble the hardware storage cabinets on page 12. But if you want to make your cabinet mobile, you'll need a set of casters.

The casters we used were 3" locking swivel casters from *Rockler* (#31870). You can also find casters available from most of the sources listed in the margin. ☘

MAIL ORDER SOURCES

Similar project supplies may be ordered from the following companies:

Rockler
800-270-4441
www.rockler.com

Casters, Flange Bolts,
Knobs, Threaded Inserts,
T-Track

Lee Valley
800-871-8158
www.leevalley.com

Casters, Knobs

McMaster-Carr
630-833-0300
www.mcmaster.com

Aluminum Bars, Casters,
Knob, Steel Tubing

Reid Tool
800-253-0421
www.reidtool.com

Aluminum Bars,
Casters, Knobs

Tool Crib of the North
800-635-5140
amazon.com/toolcrib

Fein Shop Vacuum &
Accessories

Woodsmith Store
800-835-5084

Casters, Fein Shop Vacuum
& Accessories, Knobs,
Threaded Inserts,
T-Track

Woodcraft
800-225-1153
www.woodcraft.com

Casters, Fein Shop Vacuum
& Accessories, Knobs,
Plastic, T-Track

SHOPNOTES PROJECT SUPPLIES

We now feature hardware from **ROCKLER** in many of our new project kits. To order, please use our toll-free order line, see below. It's open Monday through Friday, from 8 AM to 5 PM Central Time. Before calling, please have your VISA, MasterCard, Discover, or American Express card ready.

If you would prefer to mail in an order, please call the toll-free phone number below for more information concerning shipping charges as well as any applicable sales tax.

1-800-347-5105

ShopNotes

on the web

- "Online Extras" - Plans, Patterns, & More
- Over 100 Woodworking Tips Online
- Visit Our Woodworking Shop Tours Gallery
- Project Plans You Can Download
- Catalog of Project Kits, Tools, Jigs, & Plans
- Forums for Woodworking, Tools, & Classifieds
- Links to Other Woodworking Sites
- Order *ShopNotes* & *Woodsmith* Back Issues

www.shopnotes.com

Online Customer Service

Click on Subscriber Services at
www.shopnotes.com

- Access your account status
- Change your mailing or email address
- Pay your bill
- Renew your subscription
- Tell us if you've missed an issue
- Find out if your payment has been received

Scenes from the Shop

Extendable Drill Press Table. You don't need to wrestle with long stock at the drill press anymore. With the auxiliary table shown, the pull-out

extensions provide extra support quickly and easily. Plus, a replaceable insert provides solid support while drilling. Detailed plans start on page 26.

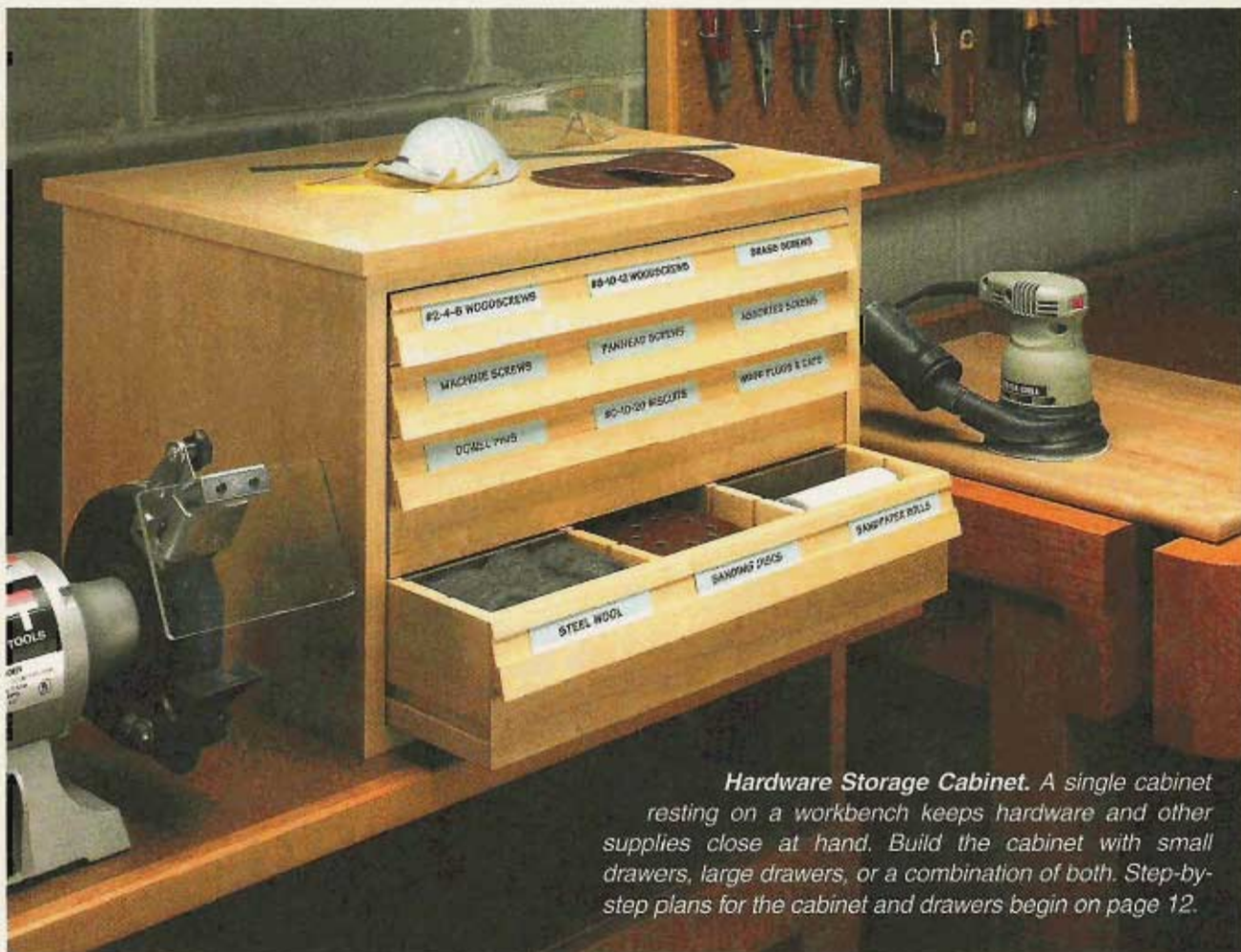
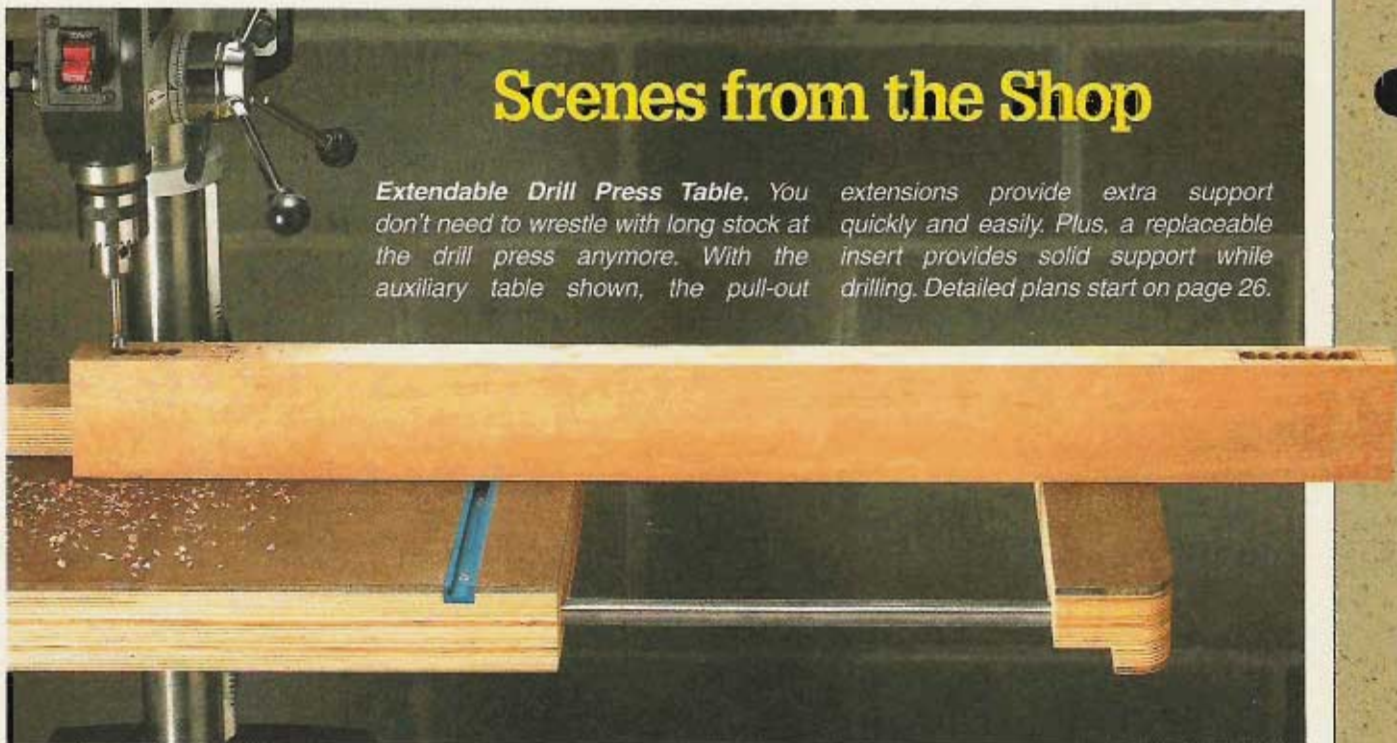

Hardware Storage Cabinet. A single cabinet resting on a workbench keeps hardware and other supplies close at hand. Build the cabinet with small drawers, large drawers, or a combination of both. Step-by-step plans for the cabinet and drawers begin on page 12.

Hardware Storage Cabinet

Materials

A Case Sides (4)	$16^{3/4} \times 14^{3/8} - 3/4$ Ply.
B Case Tops/Bottoms (4)	$16^{3/4} \times 21^{1/4} - 3/4$ Ply.
C Drawer Runners (18)	$1/2 \times 1/2 - 16^{1/2}$
D Case Backs (2)	$13^{7/8} \times 21^{1/4} - 1/4$ Ply.
E Case Edging (1)	$3/8 \times 3/4 - 24$ lin. ft.
F Top/Bottom Panel (2)	$17 \times 21^{1/4} - 3/4$ Ply.
G Panel Edging (1)	$3/4 \times 3/4 - 14$ lin. ft.
H Small Drwr. Frt./Backs (12)	$1/2 \times 2 - 19^{1/4}$
I Small Drwr. Sides (12)	$1/2 \times 2 - 16^{3/4}$
J Large Drwr. Frt./Backs (12)	$1/2 \times 4^{1/8} - 19^{1/4}$
K Large Drwr. Sides (12)	$1/2 \times 4^{1/8} - 16^{3/4}$
L Small Drwr. Dividers (12)	$1/2 \times 1^{1/2} - 14$
M Large Drwr. Dividers (6)	$1/2 \times 3^{5/8} - 14$
N Drawer Bottoms (9)	$14^{1/4} \times 19^{1/2} - 1/4$ Hdbd.
O Drawer Pulls (9)	$3/4 \times 2 - 20$
P Drawer Filler Plates (3)	$1/8 \times 2^{1/8} - 20$
Q Small Subdividers (108)	$1^{1/2} \times 6^{1/4} - 1/4$ Hdbd.
R Large Subdividers (54)	$3^{5/8} \times 6^{1/4} - 1/4$ Hdbd.

Hardware

- (72) #8 x $3/4$ " Fh Woodscrews
- (12) #8 x $1^{1/4}$ " Fh Woodscrews
- (4) #8 x 2" Fh Woodscrews
- (24) 4d Finish Nails
- (16) #6 x $3/4$ " Fh Woodscrews
- (4) 3" Locking Swivel Casters
- (16) #12 x $1^{1/4}$ " Ph Woodscrews
- (32) $5/8$ " Brads

$1/2" \times 5" - 96"$ (THREE BOARDS)

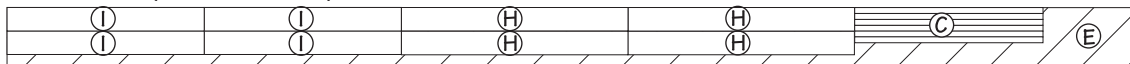

$1/2" \times 5" - 96"$ (THREE BOARDS)

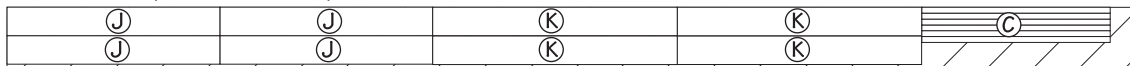

$1/2" \times 4" - 72"$ (TWO BOARDS)

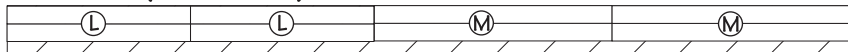

$3/4" \times 7" - 96"$



$3/4" \times 7" - 96"$



48" x 96" - 1/4" HARDBOARD

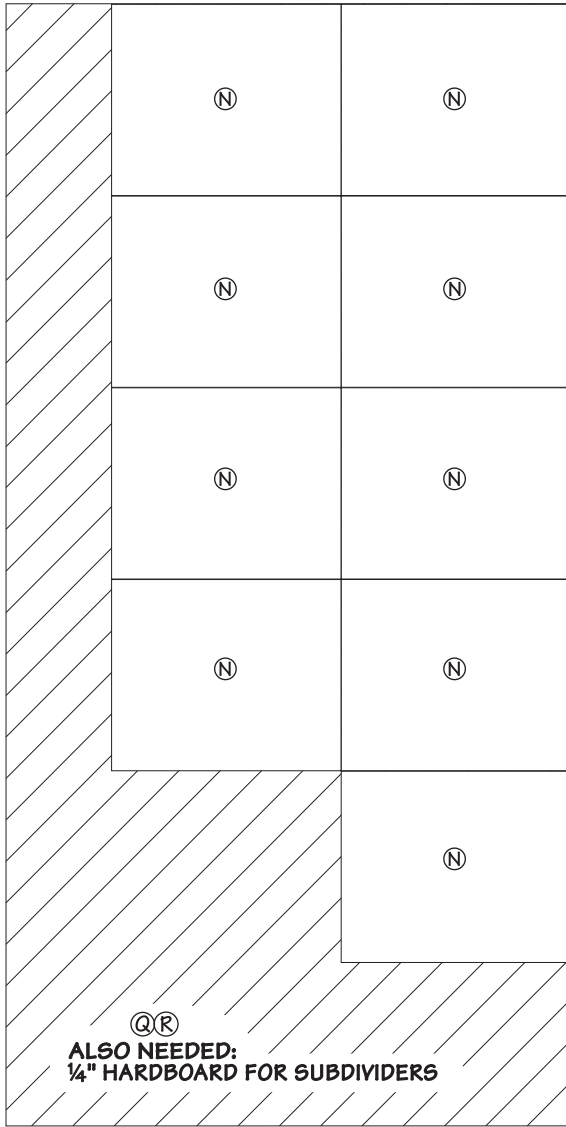

48" x 96" - 3/4" PLYWOOD

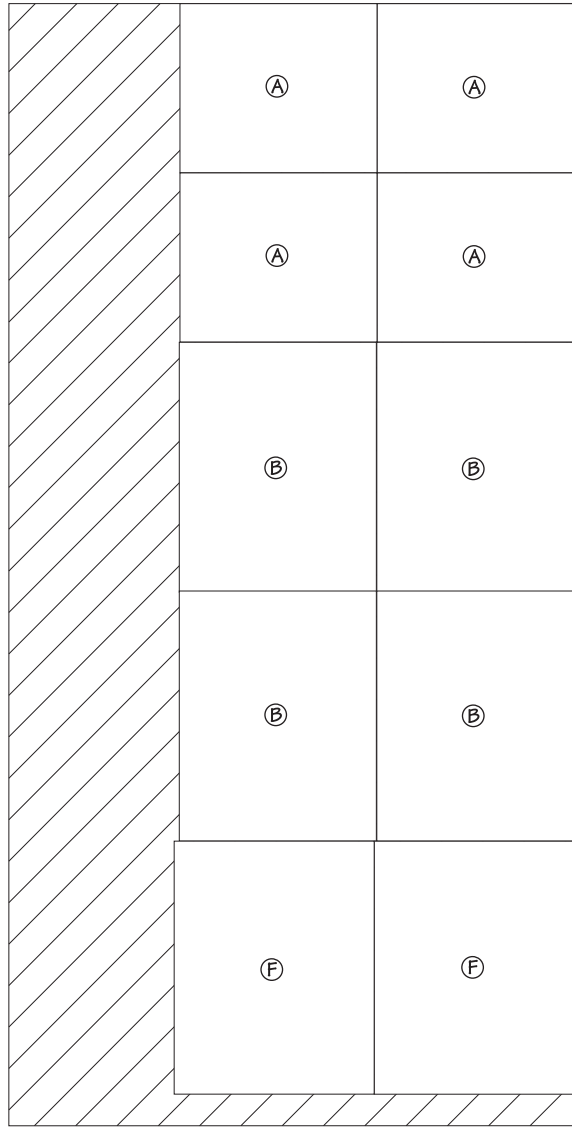

48" x 48" - 1/4" PLYWOOD

